



**Standard**  
Change-Makers, Inc.

STANDARD CHANGE-MAKERS, INC.  
3130 N. MITTHOEFFER ROAD  
P.O. BOX 36550  
INDIANAPOLIS, INDIANA 46236-0550  
PH: 317-899-6966  
FX: 317-899-6977  
[www.standardchange.com](http://www.standardchange.com)

**EC+ SERIES MACHINES**

## **Installation & Instruction Manual**

**FOR FOLLOWING MODELS:**

EC100, EC200, EC300RL, EC400RL, EC500RL-DA,

**AND OLDER MODELS OF:**

BX1000, BX1000RL,  
BCX1000, BCX1000RL



**Standard Change-Makers, Inc.**  
**Indianapolis, Indiana**

**Two-Year**  
**Limited Product Warranty**  
**EC+, BX and BCX Machine Series**

Standard Change-Makers, Inc. ("Manufacturer") warrants the machine (the "Product"), excluding any component(s) not manufactured by Standard Change-Makers, Inc. (Third Party Product(s)), to be free from defects in material and workmanship if properly installed according to the Manufacturer's Installation Instructions and serviced and operated under normal conditions according to the Manufacturer's instructions. **THE MANUFACTURER MAKES NO EXPRESS WARRANTIES WITH RESPECT TO, AND DISCLAIMS ANY IMPLIED WARRANTIES APPLICABLE TO, ANY THIRD PARTY PRODUCT(S) INCORPORATED INTO THE PRODUCT INCLUDING WARRANTIES AGAINST INFRINGEMENT, WARRANTIES OF MERCHANTABILITY AND WARRANTIES OF FITNESS FOR A PARTICULAR PURPOSE.** However, the manufacturer of Third Party Product(s) may have a warranty which is applicable to the owner of the product. Please contact the Manufacturer for additional warranty information regarding the Third Party Product(s).

No other promise or affirmation of fact concerning the Product and no other description, sample or model of the Product shall be construed as augmenting or supplementing this limited warranty, unless the additional warranty is in writing and signed by an authorized representative of Manufacturer. The warranty period commences on the date the Product is put into service ("Installation Date").

During the first twelve months after the Installation Date, Manufacturer shall repair or replace (without charge to the owner) the Product, or any component or part thereof (except Third Party Product(s)), which is determined, in the sole discretion of Manufacturer, to have defects in materials or workmanship prior to the Installation Date.

During the second twelve months after the Installation date, Manufacturer shall repair or replace the Product, or any component or part thereof, (except Third Party Product(s)), which is determined, in the sole discretion of Manufacturer, to have had defects in materials or workmanship prior to the Installation Date. During the second twelve months after the Installation Date, Manufacturer shall pay all costs for replacement parts, but the owner shall pay all labor costs.

**MANUFACTURER SHALL ONLY BE OBLIGATED TO PERFORM WARRANTY WORK IF THE PRODUCT, OR ANY COMPONENT OR PART THEREOF, IS RETURNED TO MANUFACTURERS FACTORY, OR ONE OF ITS COMPANY-OWNED SERVICE CENTERS. TRANSPORTATION CHARGES SHALL BE PREPAID BY THE OWNER.**

Each Product shipped from the factory contains Owner's Manuals. Before shipping a Product to Manufacturer or one of its company-owned service centers for warranty work, the owner shall be certain that the source of difficulty could not be corrected by performing one or more of the procedures described in the Owner's Manuals. If Manufacturer finds, in its sole discretion, that the difficulty could have been corrected by following a procedure in an Owner's Manual, **MANUFACTURER RESERVES THE RIGHT TO MAKE THEIR REGULAR CHARGE FOR ANY WORK PERFORMED.**

This limited warranty shall not apply to any Product which must be repaired or replaced because of normal wear, which has been subject to misuse, negligence, or accident, or which has been repaired or altered outside of Manufacturers factory, or one of its company-owned service centers, unless authorized by Manufacturer. Manufacturer shall not be liable for any loss, damage, or expense (including, without limitation, the loss of money caused by inadvertent machine dispense or by the use of counterfeit or bogus money) caused from or related in any way to the use of the Product or from any other cause.

No person, agent, dealer, or any other entity is authorized to give or alter any warranties on behalf of Manufacturer nor to assume for Manufacturer any other obligation or liability in connection with the Product. Manufacturer reserves the right to make design and/or operational changes to the Product without obligation to incorporate these changes in to the Product covered by this warranty.

**THIS LIMITED WARRANTY IS VALID ONLY IF AN OWNER'S WARRANTY REGISTRATION CARD HAS BEEN FULLY AND PROPERLY COMPLETED AND IS ON FILE WITH THE MANUFACTURER. THIS LIMITED WARRANTY SUPERSEDES AND IS GIVEN IN LIEU OF ALL OTHER EXPRESS OR IMPLIED WARRANTIES APPLICABLE TO THE PRODUCT, THE BILL ACCEPTOR OR BILL DISPENSER (WHETHER ARISING UNDER STATUTE, COMMON LAW, CONVENTION OR TREATY), INCLUDING WARRANTIES AGAINST INFRINGEMENT, WARRANTIES OF MERCHANTABILITY AND WARRANTIES OF FITNESS FOR A PARTICULAR PURPOSE. MANUFACTURER'S OBLIGATION TO REPAIR OR REPLACE ANY PRODUCT, OR ANY COMPONENT OR PART THEREOF, AS SET FORTH ABOVE SHALL BE IN LIEU OF ALL OTHER REMEDIES. IN NO EVENT SHALL MANUFACTURER BE LIABLE FOR INCIDENTAL OR CONSEQUENTIAL DAMAGES.**

Effective January 1, 2003



# Contents

Using This Manual: We recommend the Installation and Setup sections of this manual in their entirety before placing the machine into operation. The remaining sections are available for maintenance and troubleshooting purposes.

<b>1.0 EC+ Machine Series Description.....</b>	<b>8</b>
1.1 Specifications .....	11
<b>2.0 Changer Installation and Setup.....</b>	<b>13</b>
2.1 Cabinet Installation Instructions.....	13
2.2 Location of the Changer .....	13
2.3 Wall Mount Changers.....	13
Rear Load Changers .....	14
2.4 Mounting the Changer Cabinet .....	15
2.5 Electrical Hook-Up.....	16
<b>The Locations Electrical Supply.....</b>	<b>16</b>
2.6 EC+ Machine Module Connections .....	17
2.7 Test the Machine Operation .....	18
2.8 Lock Operation.....	18
2.8.1 “T-Handle Lock” Mechanism.....	18
2.8.2 “Plug Lock” Mechanism.....	19
<b>3.0 Machine Troubleshooting .....</b>	<b>19</b>
3.1 How To Use This Section.....	19
3.2 Troubleshooting Machine Errors.....	19
3.3 Diagnostic Indicators.....	20
3.4 Using the Diagnostic Indicators to Troubleshoot Your Machine.....	20
3.5 Frequently Asked Questions (FAQ).....	21
<b>4.0 Coin Dispenser Specifications.....</b>	<b>22</b>
4.1 Filling the Coin Dispenser with Coins .....	22
4.2 Removing the Coins from the Coin Dispenser “Bulk Dump Method” .....	22
4.3 Coin Dispenser Indicator Lights.....	25
4.4 Optional Coin Dispenser Counter .....	26
4.5 Dispenser Sold-Out Configurations .....	26
<b>5.0 Bill Dispenser Specifications (BX &amp; BCX Models Only).....</b>	<b>26</b>
5.1 Filling the Bill Dispenser.....	26
5.2 Currency Condition .....	27
5.3 Bill Dispenser Cleaning.....	27
<b>6.0 Card Dispenser Specifications .....</b>	<b>28</b>
<b>7.0 EC+ System Controller .....</b>	<b>28</b>
7.1 Description .....	28
7.2 Control Board Fuse.....	29
7.3 Status Indicator and Error Codes.....	29
7.4 5V and 24V Power Indicators .....	29
7.5 Reset Button .....	29
7.6 Dump Hopper Button .....	30
7.7 Dollars In Counter .....	30
7.8 Program Switches.....	30
7.9 Configuration Jumpers .....	30
7.10 Understanding The Machine “Operating Modes” .....	31

7.11	Setting The Machine “Operating Mode”	31
7.12	Bill/Coin Mode	32
7.12.1	Programming Mode 1 Switch Diagram	32
7.12.2	Setting the Dispensers Value	32
7.12.3	Setting the Dispenser Vend Amounts	34
7.12.4	Setting the Accumulate Value	35
7.12.5	Escrow	36
7.13	Token Mode	37
7.13.1	Programming Mode 2 Switch Diagram	37
7.13.2	Setting the Base Token Value	37
7.13.3	Setting the Bonus Token Amount	37
7.13.4	Base Token Value Table	38
7.13.5	Bonus Token Amount Table	38
7.14	Forced Dispense Override Mode	39
7.14.1	Programming Mode 3 Switch Diagram	39
7.14.2	Setting the Dispenser Value	39
7.15	Optional Setup Mode – Functional Parameters	40
7.15.1	Option mode 6 switch diagram	40
7.15.2	Bill Acceptance Settings	40
7.15.3	Bill Security Settings	41
7.15.4	Stringing Detection Settings	41
7.15.5	Auto Reset Setting	42
7.16	Fast Vend Shut Off Feature	42
7.16.1	Switch Diagram	43
7.16.2	Switch Settings When Accepting Bills \$1-\$20	44
7.16.3	Switch Settings When Accepting Bills \$5-\$100	44
<b>8.0</b>	<b>Bill Acceptors</b>	<b>45</b>
8.1	Pulse Bill Acceptors	45
8.2	Additional Bill Acceptor Information	45
8.2.1	Coinco BA30 Information	46
8.2.2	Cash Code Brand Bill Acceptor Information	47
8.2.3	MARS Series 2000 Bill Acceptors	47
8.2.4	Mars AL4 and GL4 Bill Acceptor Information	48
8.2.5	Mars VFM-1 Bill Acceptor Information	48
8.2.6	Mars VFM-2 Bill Acceptor Information	49
8.2.7	Mars VFM-3 and L005 Bill Acceptor Information	49
8.2.8	Mars VFM-4 Bill Acceptor Information	50
8.2.9	Maka NB-10 Bill Acceptor Information	50
8.2.10	Maka NB/NBE-20 Bill Acceptor Information	50
8.2.11	Dixie-Narco USA-15 Bill Acceptor Information	50
8.3	MDB Bill Acceptors	51
<b>9.0</b>	<b>Part Ordering Information</b>	<b>51</b>
9.1	Service Part Numbers	52
9.1.1	Interconnecting cables	52
9.1.2	Module Part Numbers	52
9.1.3	Coin Acceptor Kits	52
9.1.4	Universal Note Acceptor Cable Kit	52
9.1.5	Miscellaneous Parts	52
9.1.6	Coin Dispenser Type 1 Part Numbers	53
9.1.7	Coin Dispenser Type 2 Part Numbers	54

<b>APPENDIX A: EC100 Cabinet Mounting Holes and Stand Assembly .....</b>	<b>55</b>
<b>APPENDIX B: EC200 Cabinet Mounting Holes .....</b>	<b>56</b>
<b>APPENDIX C: EC200 Stand Assembly .....</b>	<b>57</b>
<b>APPENDIX D: RHINO Cabinet Mounting Holes .....</b>	<b>58</b>
<b>APPENDIX E: RHINO Stand Assembly .....</b>	<b>59</b>
<b>APPENDIX F: BCX1000 Cabinet Mounting Holes.....</b>	<b>60</b>
<b>APPENDIX G: BCX1000 Stand Assembly.....</b>	<b>61</b>
<b>APPENDIX H: Base Token Value Table.....</b>	<b>62</b>
<b>APPENDIX I: Bonus Token Amount Table.....</b>	<b>63</b>
<b>APPENDIX J: Pulse Bill Acceptor Cable Pinouts .....</b>	<b>65</b>
<b>APPENDIX K: Master Program Chip Installation Instructions .....</b>	<b>66</b>
<b>Service Centers.....</b>	<b>67</b>

# 1.0 EC+ Machine Series Description

**EC100**

**EC200**

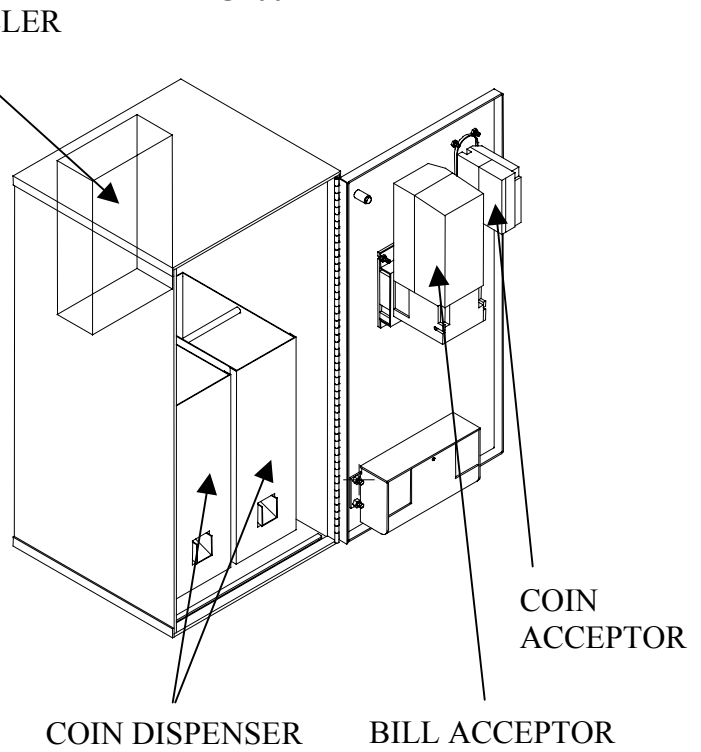
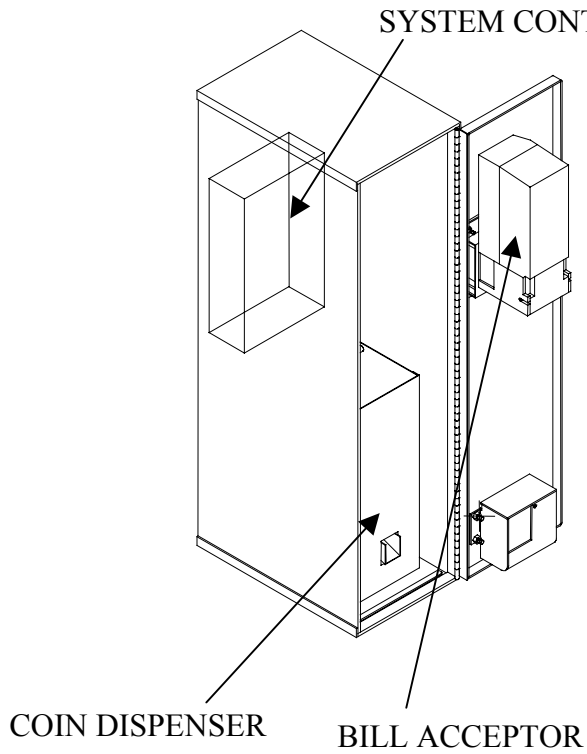

**EC300-RL**

**EC400-RL**

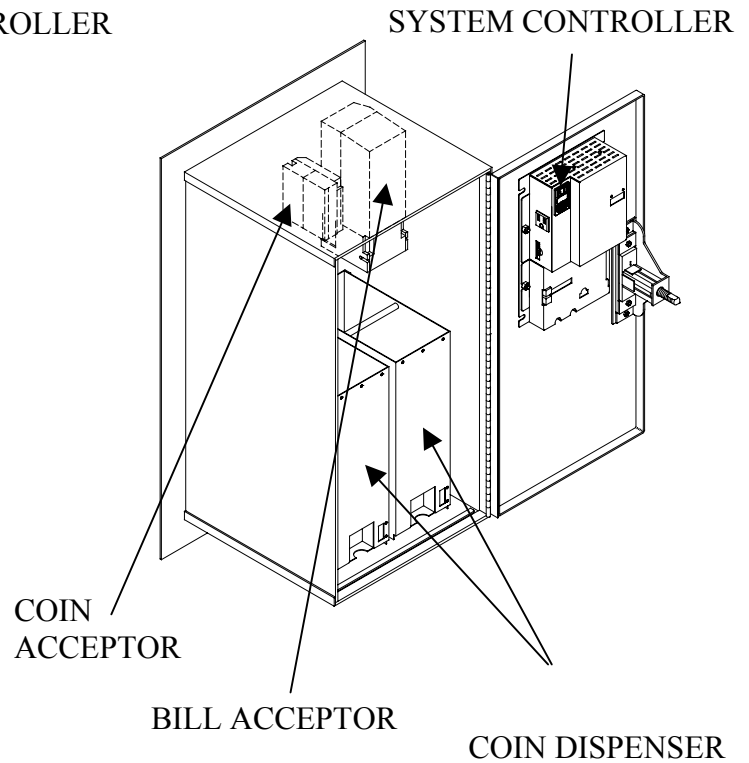
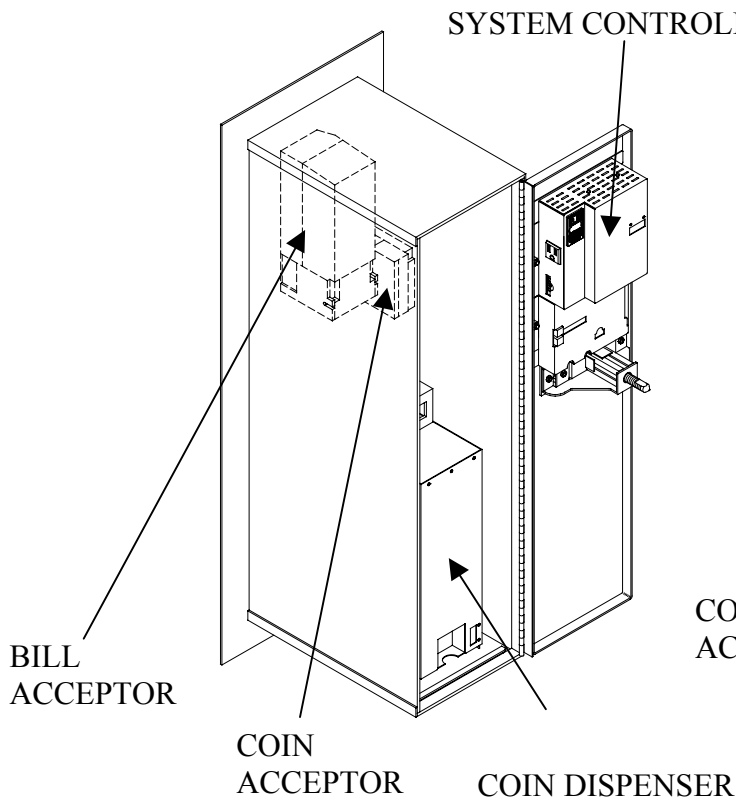



**EC500-RL-DA**

**SYSTEM CONTROLLERS**

**BILL ACCEPTOR**

**COIN ACCEPTOR**

**COIN DISPENSER**

**RHINO**

**BILL ACCEPTOR**

**COIN ACCEPTOR**

**EXTENDED COIN DISPENSER**

**SYSTEM CONTROLLER**

**Bill to Bill Exchanger**

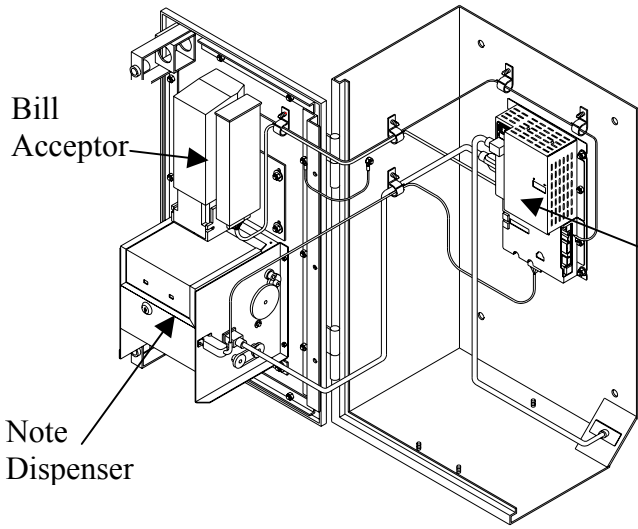

Bill Acceptor

Note Dispenser

System Controller

**Front Load Cabinet**

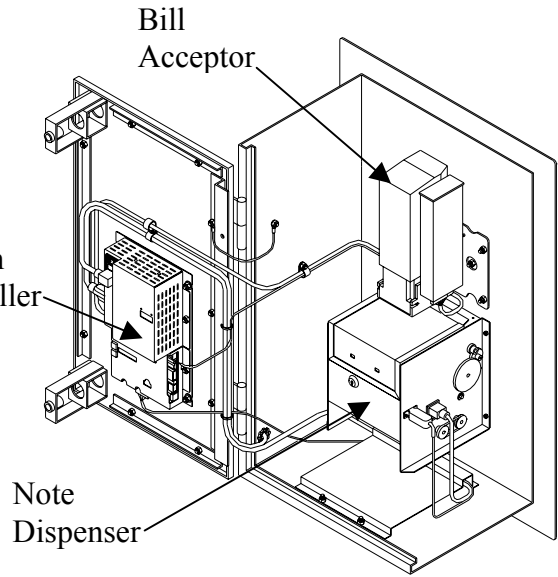

Bill Acceptor

Note Dispenser

System Controller

**Rear Load Cabinet with Faceplate**

**BCX1000**

**BCX1000-RL**

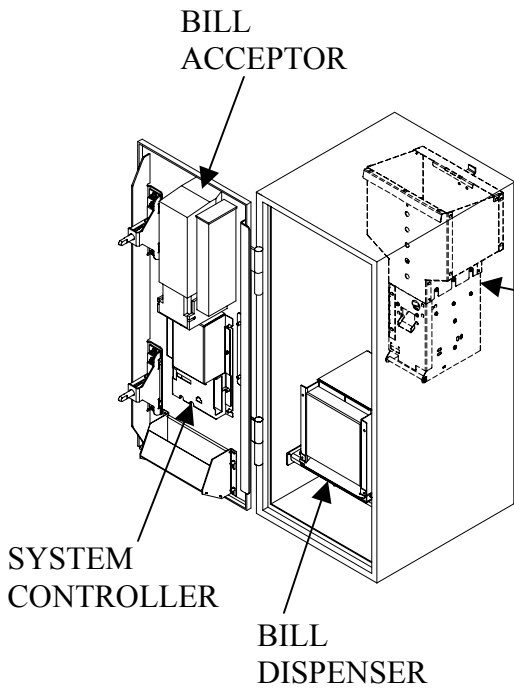

BILL ACCEPTOR

SYSTEM CONTROLLER

BILL DISPENSER

COIN DISPENSER

**Front Load Cabinet**

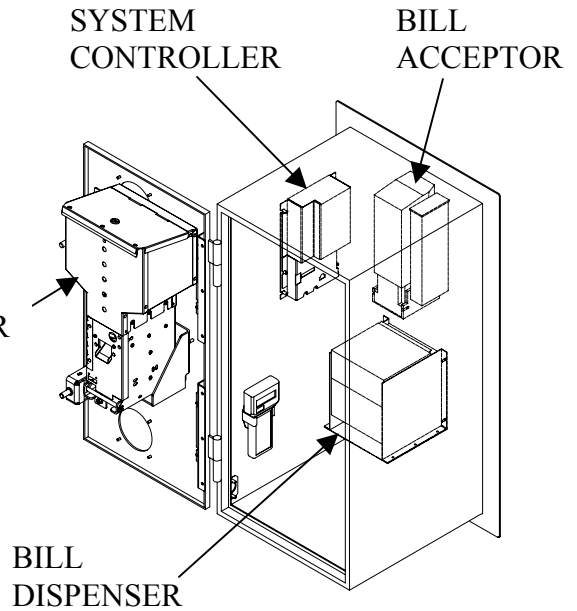

SYSTEM CONTROLLER

BILL ACCEPTOR

BILL DISPENSER

**Rear Load Cabinet with Faceplate**

The EC+ Machine Series Line uses OEM style bill and coin acceptors coupled with a highly reliable, large capacity coin dispenser. The EC+ Machine Series models differ only to the extent that some models may have one coin dispenser, others have two, some are equipped with coin acceptors and some are not.

All changers come preprogrammed from the factory to the machine owner's specifications. Programming can be easily changed by the owner using dip switches located on the system controller board or by the optional Data Terminal.

## 1.1 Specifications

Operating Voltage	120 VAC +10/-15%
Power Consumption	180W
Operating Temperature (All Models)	0° – 50°C (32 - 122°F)
Operating Temperature (Bill to Bill Exchanger)	10° – 35°C (50 – 95°F)
Interface to Coin Dispenser	See Coin Dispenser Section
Interface to Bill Acceptors	See Bill Acceptor Section
Interface to Bill Acceptors	

### EC100 Dimensions

	Width	Height	Depth	Weight
Cabinet	8.5"	32"	13"	70 lbs.
Base	8.5"	30"	13"	40 lbs.
Header	8.5"	10"	13"	10 lbs.

Header, Cabinet, and Base total height is 72"

### EC200 Dimensions

	Width	Height	Depth	Weight
Cabinet	13.5"	26"	13"	106 lbs.
Base	13.5"	30"	13"	51 lbs.
Header	13.5"	16"	13"	15 lbs.

Header, Cabinet, and Base total height is 72"

### EC300RL Dimensions

	Width	Height	Depth	Weight
Cabinet	9"	32"	13"	90 lbs.
Face Plate	13"	36"		

**EC400RL Dimensions**

	Width	Height	Depth	Weight
Cabinet	13.5"	28"	13"	131 lbs.
Face Plate	17.5"	32"		

**EC500RL-DA Dimensions**

	Width	Height	Depth	Weight
Cabinet	18"	32"	13"	175 lbs.
Face Plate	22.5"	36"		

**RHINO Dimensions**

	Width	Height	Depth	Weight
Cabinet	16.75"	27.875"	12"	133 lbs.
Base	16.75"	30.625"	12"	55 lbs.
Pedestal Base	22"	24.625"	17"	75 lbs.
Header	16.75"	13.625"	12"	15 lbs.

Header, Cabinet and Base total height is 72.125"

Cabinet and Pedestal Base total height is 52.5"

**BILL TO BILL EXCHANGER Dimensions**

	Width	Height	Depth	Weight
Front Load Cabinet	16.75"	28"	12.25"	120 lbs.
Rear Load Cabinet	16.75"	28"	12.25"	145 lbs.
Rear Load Faceplate	21"	32"		

**BCX1000 Dimensions**

	Width	Height	Depth	Weight
Cabinet	15.75"	36"	18"	175 lbs.
Base	15.75"	10"	18"	68 lbs.
Header	15.75"	26"	18"	18 lbs.

Header, Cabinet and Base total height is 72"

**BCX1000-RL Dimensions**

	Width	Height	Depth	Weight
Cabinet	18"	36"	18"	215 lbs.
Face Plate	22"	40"		

## 2.0 Changer Installation and Setup

### 2.1 Cabinet Installation Instructions

Standard Change-Makers manufactures change machines in the following cabinet styles: 1) Free standing consoles, 2) Front loading wall mount, 3) Through-the-wall rear load and 4) Slim-line vending changer. Because physical locations vary, we do not suggest an exact method of installation. To assure proper operation of your changer the following general guidelines should be observed:

### 2.2 Location of the Changer

The following points should be considered when locating a changer:

- Easily accessed by customers.
- Full swing of the door when open.
- Proper height from the floor. This will vary depending on the model of the changer. ANSI specifications for accessibility of the handicapped call for all controls, bill and coin insertion slots and coin cups to be no higher than 48 inches (1,220 mm) or no less than 15 inches (380 mm) from the floor.

If someone in a wheelchair is approaching your machine and they are not able to turn sideways to use your changer, then the user components should be no higher than 48" from the ground. If they can turn sideways, the user components on the changer can be raised up to 54".

- This machine is designed for use in protected locations. It should be installed in such a way as to prevent it from being directly exposed to the outdoor environment. Standard Change-Makers, Inc. recommends the use of an awning, canopy, or other protective screen to prevent machine damage from exposure to the weather. It is also recommended that all open holes on the cabinet be sealed to prevent water intrusion.

### 2.3 Wall Mount Changers

Type of wall construction: For maximum security, it is recommended that the changer be installed on a wall made of cement block, brick or other type of masonry. A wooden stud wall is acceptable but will not provide the security or strength usually associated with masonry. The mounting holes on the back of the changer will accommodate four 1/4-inch diameter bolts. See Appendix A for EC100 and Appendix B for EC200 mounting hole patterns.

#### **WARNING!**

**CHANGERS MOUNTED ON BASES ARE TOP HEAVY**  
The changer **MUST** be secured to a rigid vertical surface, as well as to the stand to provide appropriate security, stability, and safety.

If the wall to which the changer will be mounted does not meet the construction standards above, we recommend using the Standard Change-Makers stand. The stands are provided with mounting holes on the top surface for mounting the changer and holes are also provided on the bottom for securing the stand to the floor. A drill template is included with each stand. When using the stand, we recommend that the changer be bolted to the wall as well as to the stand. This provides a highly secure installation. See Appendix A, C, E and G for the stand assembly diagrams.

#### **CAUTION**

We do not recommend welding the cabinet to any kind of mounting. This can cause unwanted warping of the cabinet as well as internal component damage.

If the changer is to be mounted to a post, the post should be sunk in concrete for stability. It is also recommended that the post be filled with concrete for strength. A steel plate with approximately the same dimensions as the changer should be welded to the post. Bolt the changer to the steel plate through the four 1/4-inch mounting holes drilled into the plate. Tack weld the heads of the mounting bolts to prevent their removal. Four nuts and washers inside the changer can then secure the changer. If this method is not feasible, the bolts can be bent after installation to prevent removal.

## Rear Load Changers

A rear load changer cabinet must mount through a hole in the wall. The stainless steel front plate, which extends 2 inches beyond the cabinet on all sides, must be tight against the wall surface. The cabinet will be 13"-18" deep. Its protrusion into the back room will be the difference between this depth and the thickness of your wall. Allow for proper door swing. Also, lay a bead of caulking inside the front plate before installation to prevent moisture incursion.

Angle iron mounting brackets are available to secure the changer in place. One side of the angle iron should be secured to the side of the cabinet. The other side of the angle iron mounts to the wall. The installed angle irons will provide additional support needed to minimize cabinet flexing when the door is opened.

Some rear load models have the coin hoppers mounted on the door. When the hoppers are full and the door is opened, a significant load occurs on the cabinet. This load can result in cabinet flexing if the cabinet is not sufficiently supported. Repeated flexing of the cabinet can result in metal fatigue and stressed weld joints on the cabinet.

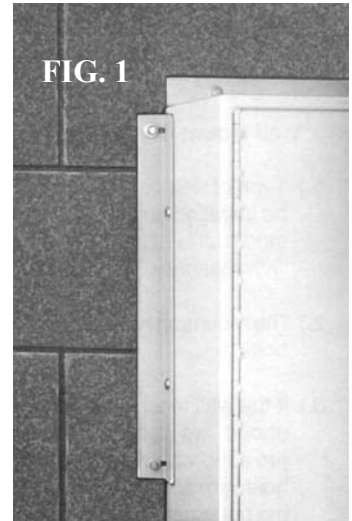

When the cabinet is installed in a cinder block wall, as shown in Figure 1, the block wall will typically provide enough support on the sides and bottom of the cabinet to prevent flexing. In locations where this type of mounting is not feasible, for example a 2x4 stud wall, additional support is required. To sufficiently support the cabinet, at least 75% of the cabinet bottom should be supported with load-bearing, non-flexing material such as cinderblock or iron. In addition, the sides of the cabinet must also be supported to prevent the cabinet from twisting when the door is opened. See Figure 2 for the required support areas.

**Any deviation of these guidelines will void the machine's warranty.**

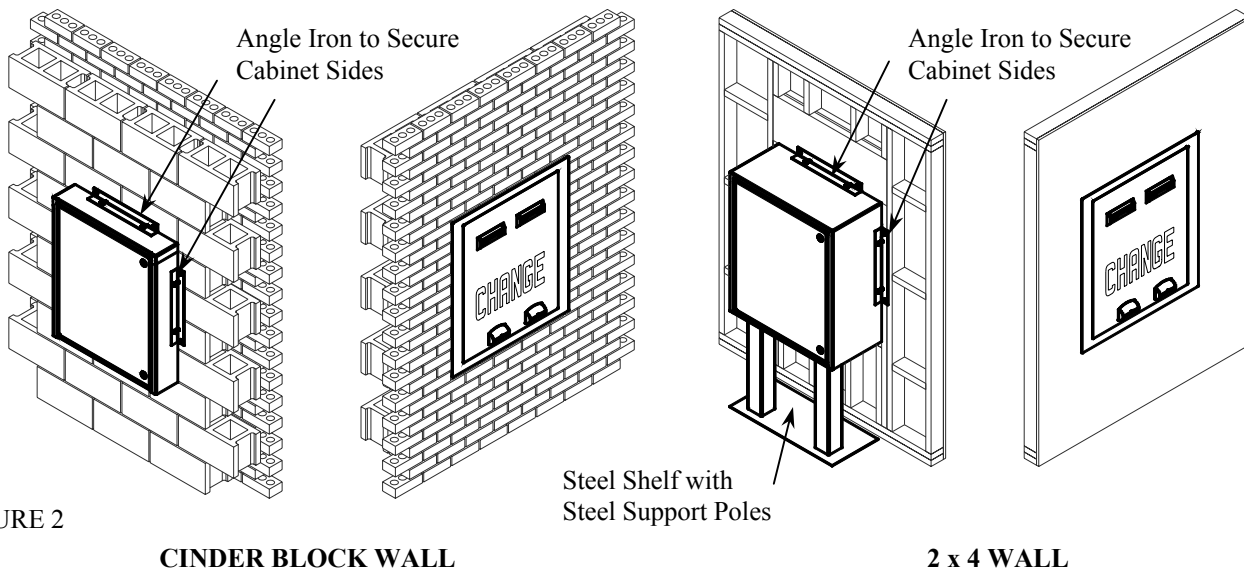

FIGURE 2

CINDER BLOCK WALL

2 x 4 WALL

**CAUTION:** We do not recommend welding the cabinet to any kind of mounting. This can cause unwanted cabinet warpage as well as internal component damage.

## 2.4 Mounting the Changer Cabinet

If your machine was shipped with the coin dispensers in place, the dispensers should be removed before installation. If the coin dispensers have been shipped in separate carton(s), do not remove or disconnect any components.

Use four 1/4-inch diameter bolts for mounting.

### **CAUTION**

Even the slightest uneven surface can cause cabinet distortion when mounting bolts are tightened. This can cause the doors to fit unevenly when closed. This distortion can occur even more easily on large cabinets. Should this occur, it may be necessary to shim one or more of the cabinet corners.

- Make sure that the cabinet is level and the mounting surface is flat.
- Be sure that the inside of the cabinet is free of metal shavings and other debris, which might have been introduced in the mounting process.
- Remove all packing materials and shipping straps from the cabinet. Some items have yellow tags with removal instructions.
- After installation, replace coin dispenser(s) or, if they were shipped separately, remove them from their cartons and install them. Plug in all electrical connectors.

## 2.5 Electrical Hook-Up

The EC+ Machine Series cabinet comes pre-wired. The changer need only be connected to a properly grounded electrical outlet. (3<sup>rd</sup> wire ground back to main service panel) We also recommend that the changer be wired on a dedicated line. A dedicated line is a circuit which has no other equipment connected on the same circuit breaker or fuse. The purpose of a dedicated line is to reduce the possibility of line interference, which may cause the changer to malfunction. Some models have several cut outs allowing alternate wiring inlets.

### IMPORTANT

This machine must be grounded through a properly installed 3<sup>rd</sup> wire ground which extends intact to the main service panel.

### The Locations Electrical Supply

If this machine has a service cord that ends in a 3-pin connector. The wall receptacle you plug the machine into must be properly polarized and grounded. Operating your machine from an improperly connected power source will VOID THE WARRANTY. The wall receptacle must be able to supply a constant 120 volts at 60Hertz. The receptacle should be protected by a 15 amp circuit breaker or fuse. The machine should have its own electrical circuit. Perform checks on the power source as follows: (See photo below)

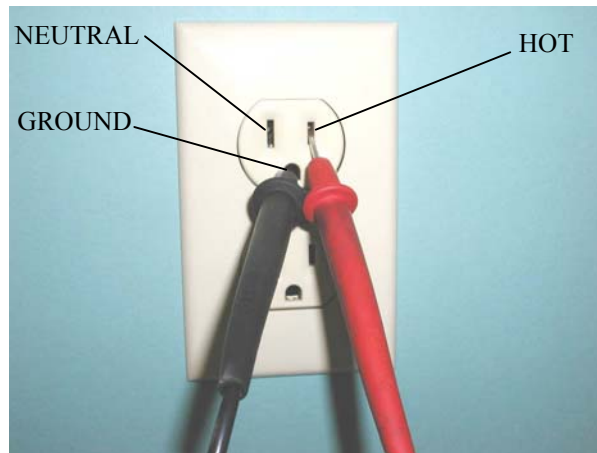

#### 1. Voltage Check

When placed across the **HOT** and **NEUTRAL** terminals, a volt-ohmmeter should indicate 110-130 volts AC.

#### 2. Polarity Check

When placed across the **HOT** and **GROUND** terminals, a volt-ohmmeter should indicate 110-130 volts AC.

#### 3. Noise Potential Check

When placed across the **NEUTRAL** and **GROUND** terminals, a volt-ohmmeter should indicate no more than .5 volts AC. Readings greater than .5 volts AC indicate a poor grounding condition that could result in noise problems for the electronic circuitry.

If you are hard wiring the changer the same checks should be performed on the supply line going to the changer. Any deviation from these requirements may result in unreliable performance from your machine.



## 2.6 EC+ Machine Module Connections

Check the connections for all machine modules before proceeding. See the diagram below for location of plugs and connectors.

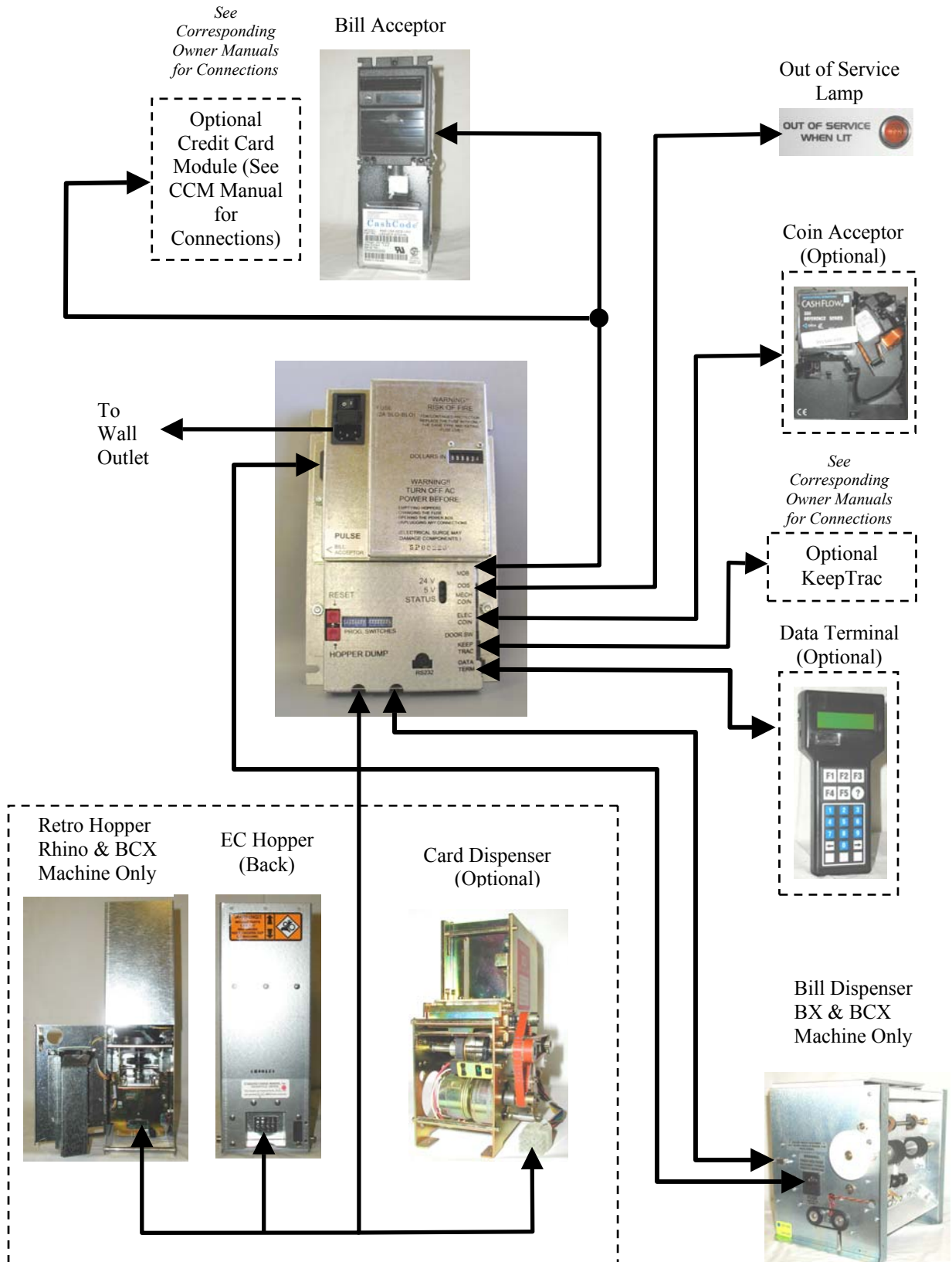

**NOTE:** An improperly connected machine may void your warranty.

### **A WORD ABOUT GROUNDING**

Please make sure your changer has a good ground. Improper grounding of the changer will cause erratic operation and is unsafe for the people using the changer.

## **2.7 Test the Machine Operation**

When installation is complete, test each machine function for proper payout and operation. If you wish to change the programming of the machine, turn to section 6.10 and follow the instructions. If you have the Data Terminal option please refer to Data Terminal Instruction Manual included with your machine.

## **2.8 Lock Operation**

### **2.8.1 “T-Handle Lock” Mechanism**

The T-handle lock that the EC Machine Plus is equipped with provides quick and easy access to the interior of the changer with maximum security. To disengage the lock it is only necessary to unlock the mechanism and turn the handle counter clockwise until it disengages from the interior lock mechanism (approximately five turns), then pull the door open. The lock handle must be parallel to the floor for the lock to disengage on EC100, EC200, EC400RL and RHINO cabinets; the lock must be perpendicular to the floor on the EC300RL and EC500RL-DA cabinet. To lock the door, turn the handle parallel to the floor then push the door closed. The lock will be automatically engaged as the door is closed. If the door is pushed all the way closed it will be only necessary turn the handle a couple of turns until the lock tightens. The lock handle can then be pushed into the recess of the door, securely locking the cabinet.

### **WARNING!**

Do not place cabinet lock keys inside the changer as they may be inadvertently locked inside.

**SUGGESTION:** Place a duplicate key to the changer in a safe place in the event it is needed at a later date.

Note: On the Rhino changer, remove the 2 screws in the bottom of the change box to allow the box to be removed to dump the coins.

### 2.8.2 “Plug Lock” Mechanism

The Plug lock that the EC+ Machine Series is equipped with provides quick and easy access to the interior of the changer with maximum security. To disengage the lock it is only necessary to unlock the mechanism and using the lock crank wrench, turn counter clockwise until it disengages from the interior lock mechanism (approximately five turns), then pull the door open. To lock the door, turn the lock crank wrench clockwise until the lock tightens. Then re-insert the plug lock all the way into the recess of the door and turn key until it locks and remove.

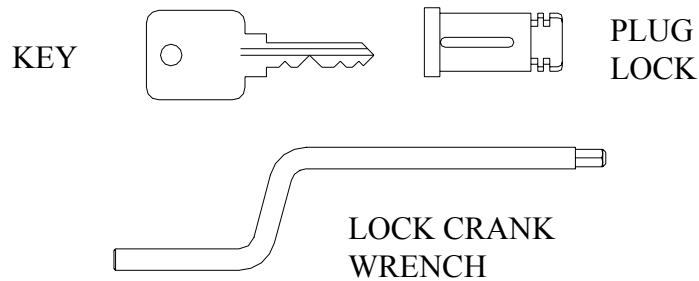

## 3.0 Machine Troubleshooting

### 3.1 How To Use This Section

This section is used to determine which module (hopper, controller, bill dispenser...) requires testing, adjustment or repair. Once the module has been identified, you will be directed to the detailed troubleshooting section of the manual that pertains to the module in question. In some instances, a separate manual will be referenced.

### 3.2 Troubleshooting Machine Errors.

The EC Plus line incorporates diagnostic indicators (LED's) on most internal components as well as a standard Out-Of-Service light for the front of the machine. An optional data terminal can be purchased with an EC premium upgrade, which gives the owner a complete list of error codes and programming options. *A Data Terminal programming instruction manual is included with this optional upgrade.*

### 3.3 Diagnostic Indicators.

**Out Of Service light** is used to indicate to the machine owner that either an error has occurred or that the machine is in a sold out status. A solid light indicates that an error has occurred and that the machine must be serviced. A flashing light indicates that the hopper(s) are sold out (empty) and more coins/tokens must be added.

**System Control Board Indicator lights** are used to determine the status of the machine. In normal operation, the status light will flash quickly in a steady pattern. If an error should occur, the status light will flash intermittently indicating the failure mode. See section 5.8 for a complete listing and description of error codes.

**Coin/Token Dispenser Indicator lights** are used to determine the status of the coin or token hopper. These lights (LED's) can be viewed through a small opening to the right of the coin chute. The center light is off during normal operation. If an error should occur, the status light will flash intermittently indicating the failure mode. See section 3.4 for a complete listing and description of error codes.

**Bill Acceptor Indicator lights** are included on most OEM bill acceptors that are now available. The location and description of these lights can be found in the Bill Acceptor manual included with this machine.

### 3.4 Using the Diagnostic Indicators to Troubleshoot Your Machine

Our EC plus based product is highly reliable but at some time or other, you will need to be able to troubleshoot your machine. A typical troubleshooting scenario would be as follows:

1. O.O.S. light on solid.
2. View flash code on EC plus controller.
3. Review flash code table (see section 5.8).
  - A. Flash code 1 –Illogical switch selection.  
Check Switch setting by referring to section 5.4 Programming Mode.  
Check for unplugged hopper or bill dispenser cable.
  - B. Flash code 2-4, 6-8, 10-12,15.  
Indicates a possible hopper problem.  
Review hopper flash code table (see section 3.4).
  - C. Flash Code 5  
Check for jam bill (see section 4.3 for cleaning instructions).  
(BX and BCX machines only)  
Card Machine only – Check for stuck card.
  - D. Flash Code 9 –Bill Acceptor Error.  
Review Bill Acceptor flash code table (see Bill Acceptor manual).
  - E. Flash Code 13 –Fast vend shut off.  
Indicates unusual usage. Audit your machine and inspect  
Bill Acceptor for tampering.
  - F. Flash Code 16 – Power loss during a dispense  
Indicates that a faulty power line is present. This should be corrected as it can result in  
erratic payouts.
4. Reset the machine and test for proper operation.

### 3.5 Frequently Asked Questions (FAQ)

An owner can typically resolve many problems after he/she has been familiarized with our machine. The following are a few examples of questions and answers you may have concerning our equipment.

- My out of service light is blinking and the machine won't take a bill! *A flashing OOS light indicates a hopper sold out condition. Add enough coin/tokens to cover the black funnel inside the hopper.*
- My bill acceptor is rejecting too many bills! *Bill rejection can be caused by dirty sensors. Open up the bill path and clean the sensors and rollers. Also, check with the bill acceptor manual for error code and troubleshooting information.*
- How do I turn on or off the acceptance of certain bills? *Refer to the section containing information on option switches in the Bill Acceptor manual. There will be an illustration of the options available for that unit.*
- My Out-Of-Service light is on solid and the machine won't take a bill! *Refer to section 3.3 to review diagnostics available to isolate the problem.*
- My acceptor takes the money, but the hopper won't dispense change! *Verify that the dollars-in counter on the controller advances each time a bill is accepted. If not, check the acceptor power cable for loose wires or for a bad connection. If the counter does advance, check the hopper status LED for a flash code indication. Dump the hopper and press the "hopper dump" button and verify that the feed mechanism is rotating. If not, refer to the exploded views 8.16 and 8.17 in the back of this manual for parts information.*
- I want to switch to dispensing tokens. How can I do that? *EC Plus base products handle dispensing tokens very effectively. To minimize your costs, choose a token with the same dimensions of the coin you currently are dispensing. This keeps you from needing to change your hardware. Review the Mode 2 Programming section in section 6.13 of this owner's manual for more information.*
- My Bill Dispenser is jamming too often. *Bill jams are typically caused by the condition of the currency being dispensed. ATM quality currency is strongly recommended and will limit jamming problems. In addition, worn or dirty rollers can cause bill jamming. Refer to section 5.3 –Bill Dispenser Cleaning for more information.*
- I need to send you a part for repair. Do I need a RMA number? *(Return material authorization number). No, we only ask that you include your name, phone number, address and a brief description of the failure. We will process and return your product ASAP.*
- I need to upgrade the software in the controller. Can I do this myself? *Software revisions for the Economy Controller are not common. But as new features are added you may decide to upgrade your changer. Appendix K in the back of this manual will guide you through this easy process.*
- What happens to my Bill & Coin Machine if the bill dispenser sells out (empties)? *There is an automatic transfer function that is if it senses a bill dispenser sold out condition, the remaining money is dispensed from the coin hopper. All additional vends will be from the coin hopper until that hopper also sells out. Refilling the machine will automatically "reset" the machine to the normal payouts from the bill dispenser and coin hopper.*

## 4.0 Coin Dispenser Specifications

### **!! CAUTION !!**

Never place your fingers in or near the coin dispense chute of the coin dispenser.

### 4.1 Filling the Coin Dispenser with Coins

Filling the coin dispenser is a simple task. The coin dispenser may be removed and filled outside the machine or they may be left in the machine and filled with coins. For coins contained in a bank bag, grasp the neck of the bank bag and twist it to choke the mouth of the bag. Invert the bag and insert the neck of the bag into the top of the coin dispenser. Loosen your grip on the bag neck slowly, letting coins feed down into the dispenser. Table 3.1.1 gives a convenient filling level for the various standard coin dispensers. When possible, you can turn your bank bags inside out and lessen the chance of small strings and threads from accumulating in your coin dispenser. Clean coffee cans or plastic pails can also be used to fill the coin dispensers.

Table 3.1.1

	Type 2 Standard Capacity Hopper		Type 1 Extended Capacity Hopper		Type 3 Double Capacity Hopper		
	Type	No. of Coins	Value	No. of Coins	Value	No. of Coins	Value
Quarter Dispenser		3,200	\$800	3,800	\$950	6,400	\$1,600
Dollar Dispenser		2,400	\$2,400	2,850	\$2,850	4,800	\$4,800
Nickel Dispenser		3,800	\$190	4,500	\$225	7,600	\$380
Dime Dispenser		7,800	\$780	9,300	\$930	15,700	\$1,570

### **IMPORTANT**

The correct coin must be poured into each coin dispenser. The coin dispensers are marked to indicate which coin they will dispense. Never mix coins or allow foreign material to fall into the coin dispensers.

### 4.2 Removing the Coins from the Coin Dispenser “Bulk Dump Method”

To remove coins manually in an EC100 or EC200 cabinet - TURN POWER OFF then pull the coin dispenser forward approximately 1 inch using the slide handle at bottom of the cabinet. Sliding the dispenser forward will disengage the electrical connections and allow the coin dispenser to be tilted forward for dumping the coins into a suitable container or bag. To tilt the coin dispenser pull forward at the top edge of the dispenser.

To remove coins manually in an EC300RL, EC400RL, or EC500RL-DA cabinet - TURN POWER OFF then pull the coin dispenser power cable from the bottom of the dispenser. The coin dispenser power cable must be removed to prevent it from being damaged when the dispenser is tilted out. Tilt the coin dispenser back for dumping the coins into a suitable container or bag. To tilt the coin dispenser, pull back at the top edge of the dispenser.

To remove the small number of coins that remain in the coin dispenser, perform a “Sold Out” dump. See the next section for details.

**Type 1 Coin Dispenser Dump EC100 and EC200**

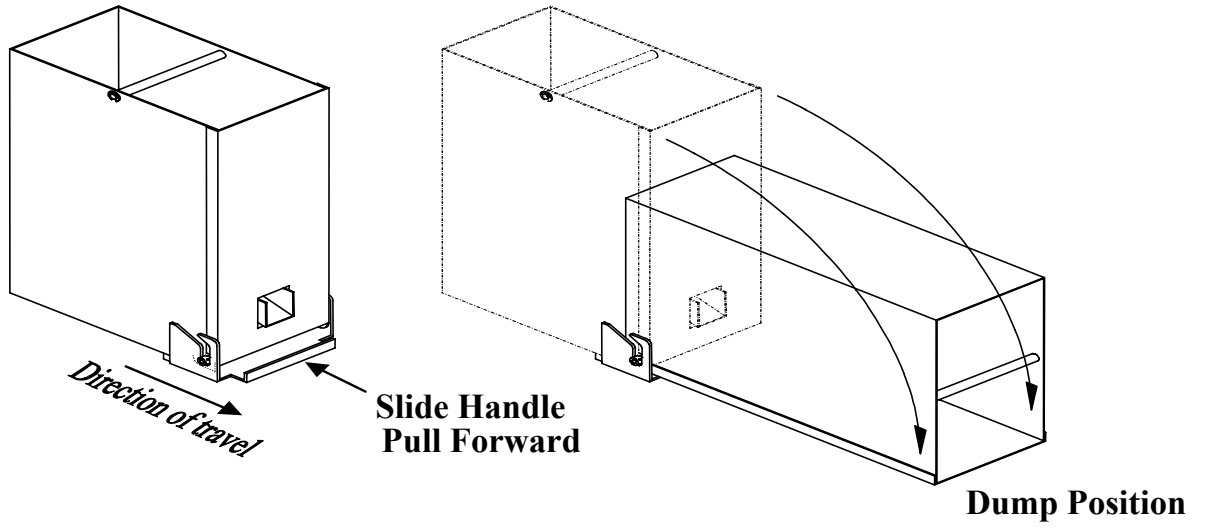

**Coin Dispenser Dump EC300RL, EC400RL, and EC500RL-DA**

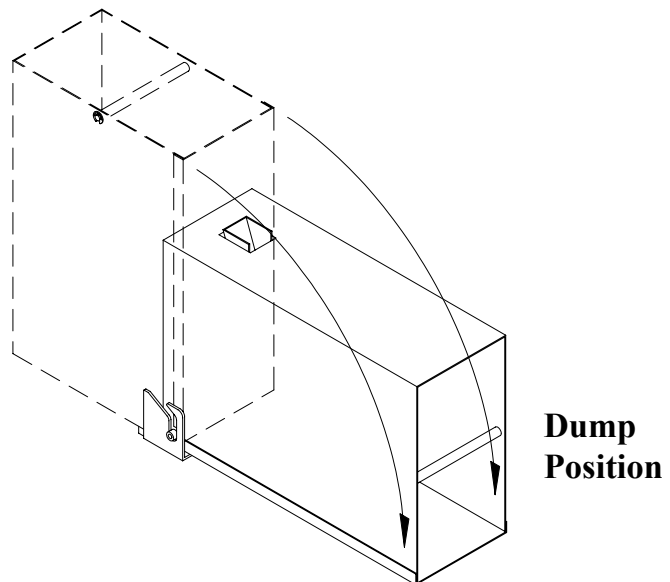

**Type 2 Coin Dispenser Dump - Rhino**

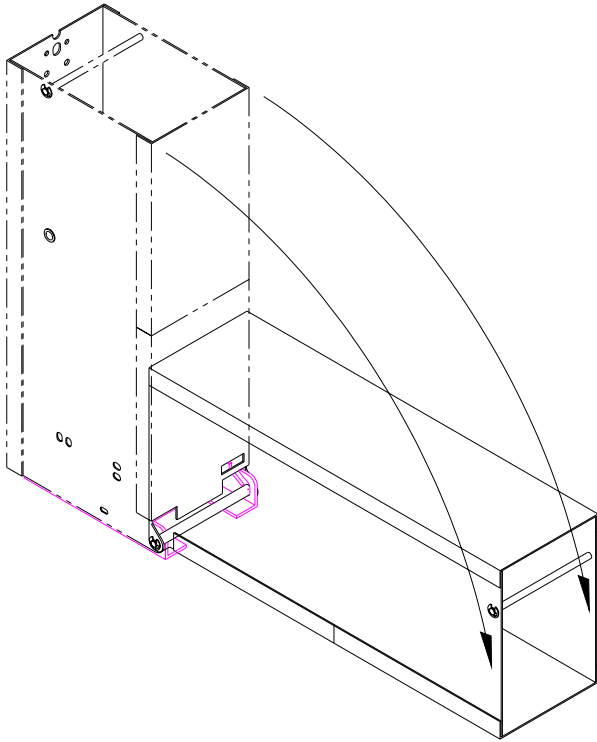

**Dump  
Position**

**Type 3 Coin Dispenser Dump BCX1000**

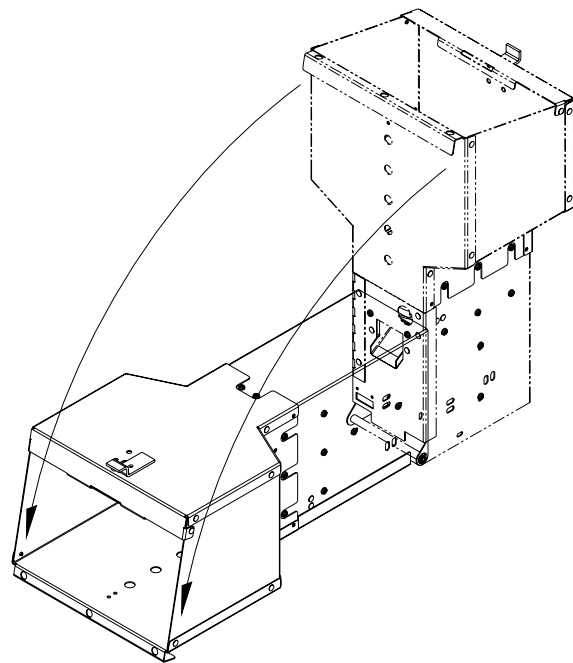

**Dump  
Position**



### 4.3 Coin Dispenser Indicator Lights

The Coin Dispenser indicator lights show the status of the dispenser. See photos below for locations of LED's.

**Power LED**

ON                      Power is connected to the dispenser  
 OFF                     No Power

**Error LED**

FLASHING             ERROR: dispenser lockup or any other dispenser errors see dispenser flash code table.  
 OFF                     Normal operation

Coin Dispenser Flash code table:

Flash code	Error
0	Normal Operation
1	Coin sensor blocked by coin or dirt
2	Coin Dispenser Lockup
3	Coin Dispenser Jackpot
5	Coin Dispenser Overpay
6	Coin sensor Blinded by excessive light

**Coin LED**

ON                      Normal - Flashes off when a coin passes through the interrupter

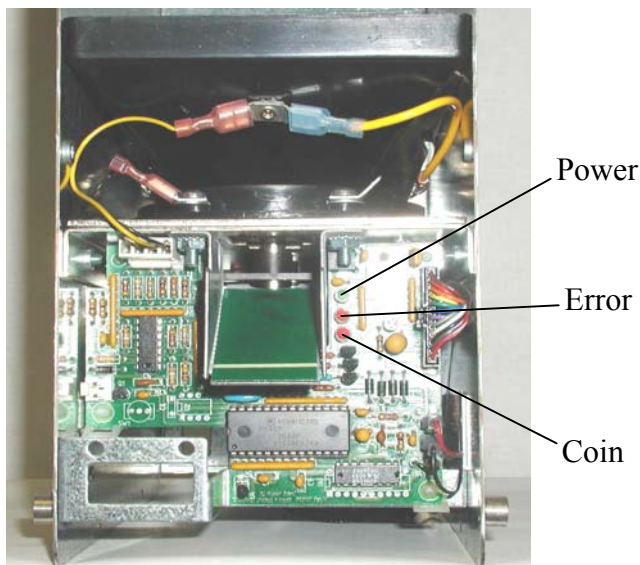

**Type 1 Coin Dispenser**

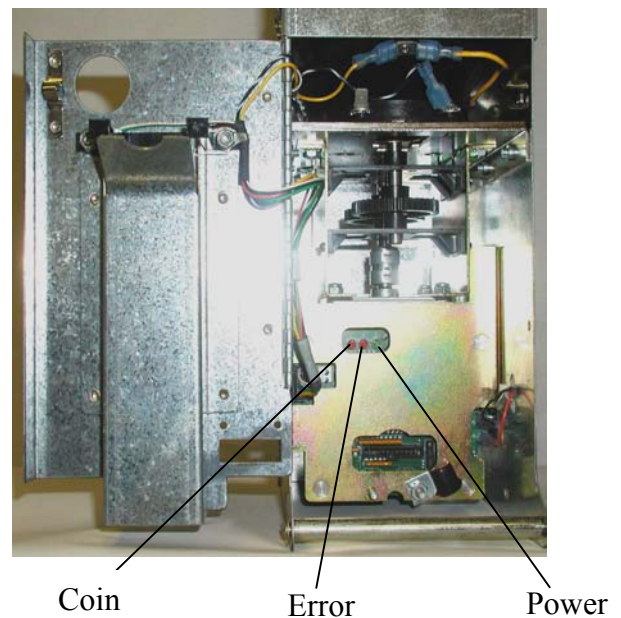

**Type 2 Coin Dispenser**

## 4.4 Optional Coin Dispenser Counter

The Optional Coin Dispenser Counter is a non-resettable counter that indicates the number of coins dispensed. One count equals one coin.

## 4.5 Dispenser Sold-Out Configurations

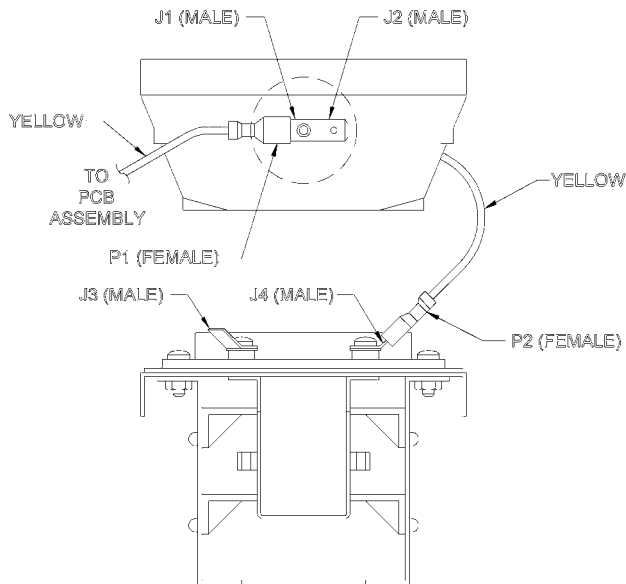

### NOTES:

Connections are shown as a standard coin dispenser setup of a \$20 sold-out. To change connections remove the front cover plate from the dispenser. The coin dispenser must be empty before removing the cover plate.

To set up for a \$5 sold-out condition, unplug P2 from J4 and connect P2 to J2.

To completely bypass the sold-out contacts connect P1 to J3

## 5.0 Bill Dispenser Specifications (BX & BCX Models Only)

### 5.1 Filling the Bill Dispenser

1. Unlock the locking mechanism on the back of the bill dispenser module.
2. Remove the bill box from the top of the bill dispenser module by lifting up the back of the bill box and sliding the bill box out. Note: Some bills may be left in the dispenser module that they can be removed by gently pulling the bills out from between the rollers.
3. Place bill box on a table with the open side up.
4. Place bills to be loaded on to the top of the bill box then gently press them down into the bill box. It is important that the edges of the notes be reasonably aligned prior to insertion into the cassette. Ensure that there are no folds that overlap neighboring notes. For best results, the notes should be loaded into the cassette in 50-100 note batches. Loading the cassette in larger batches can cause the edges of the notes to fold up as they are inserted.
5. Reload bill cassette into the bill dispenser.

Approximate capacity for the bill dispenser is 1000 new condition bills.

**NOTE:** Special care should be taken when filling the bill dispenser. An improperly loaded bill cassette can cause frequent bill jams.

## 5.2 Currency Condition

Optimum performance of the bill dispenser is achieved if the note condition is limited to ATM fit or good teller grade currency. Torn, taped or curled bills should be culled out. Broken packages (bricks) of new currency mixed with circulation notes will feed but increase the possibility of stoppages. The use of broken packages (bricks) alone or in significant quantities is not recommended.

**\*Dispensing \$1.00 bills is not recommended due to the general condition of the circulated bills. ATM quality \$1.00 bills are not readily available.**

## 5.3 Bill Dispenser Cleaning

The feed, picker and conveyor rollers must be cleaned on a regular basis. It is required that these surface's be cleaned at least every 5000 dispenses. The feed rollers can be cleaned by pressing an isopropyl alcohol dampened wipe into the gap where this roller is visible while depressing the run button. This should be repeated two or three times on fresh areas of the alcohol wipe. The picker and conveyor rollers should be cleaned in a similar manner. The rollers can also be cleaned as described above by turning the motor pulley instead of using the run switch.

**CAUTION: USING CLEANING AGENTS OTHER THAN ISOPROPYL ALCOHOL MAY PERMANENTLY DAMAGE THE ROLLERS.**

**CAUTION!**  
**Do not run the bill dispenser feed mechanism without bills for an extended period of time.**  
**Damage may result.**

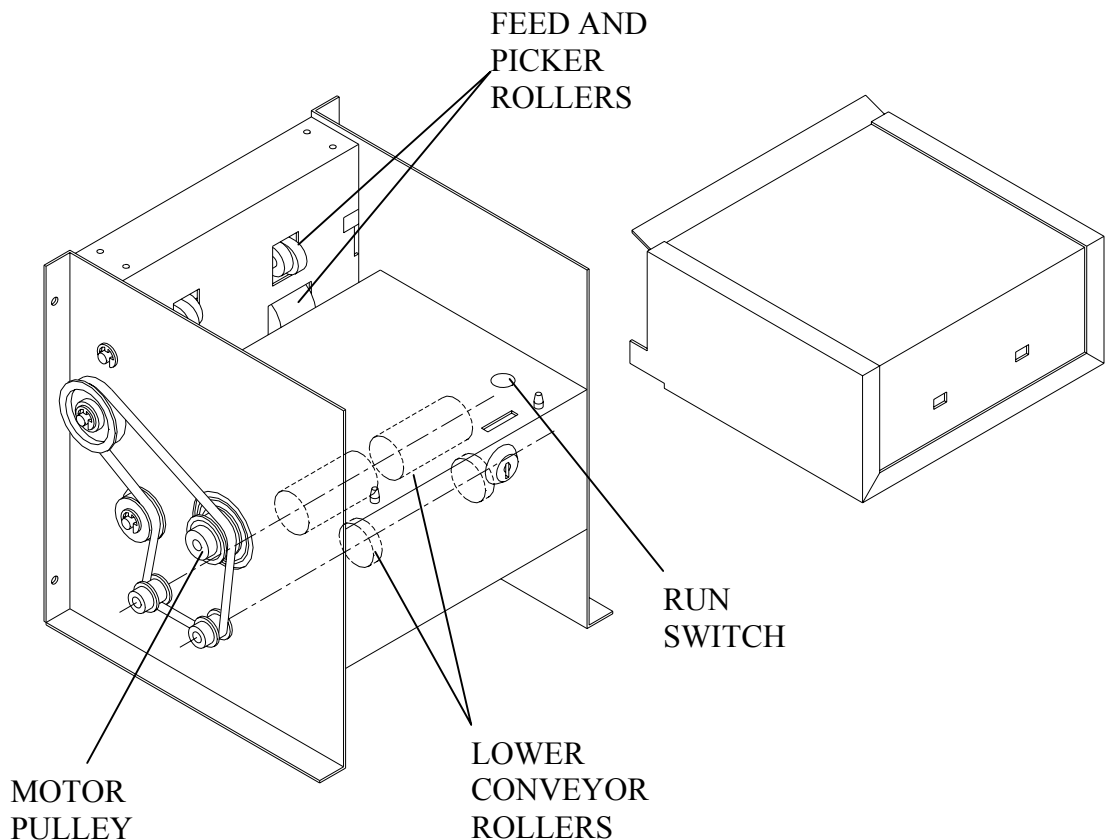

## 6.0 Card Dispenser Specifications

See Card Dispenser Service manual for more information.

## 7.0 EC+ System Controller

### 7.1 Description

The EC+ System Controller manages (controls) all other modules in the machine (bill acceptor, hopper, bill dispenser...). This module also provides an interface (program switches) that can be used to change the basic “operating modes” of the machine and to reconfigure the machines existing hardware modules, or to configure new hardware modules should one be added. In addition this module provides the owner with useful machine diagnostic information.

For a complete list of the features associated with this module, read the remainder of this section. The picture below shows the location of each item referenced in this section: program switches, buttons and indicators...

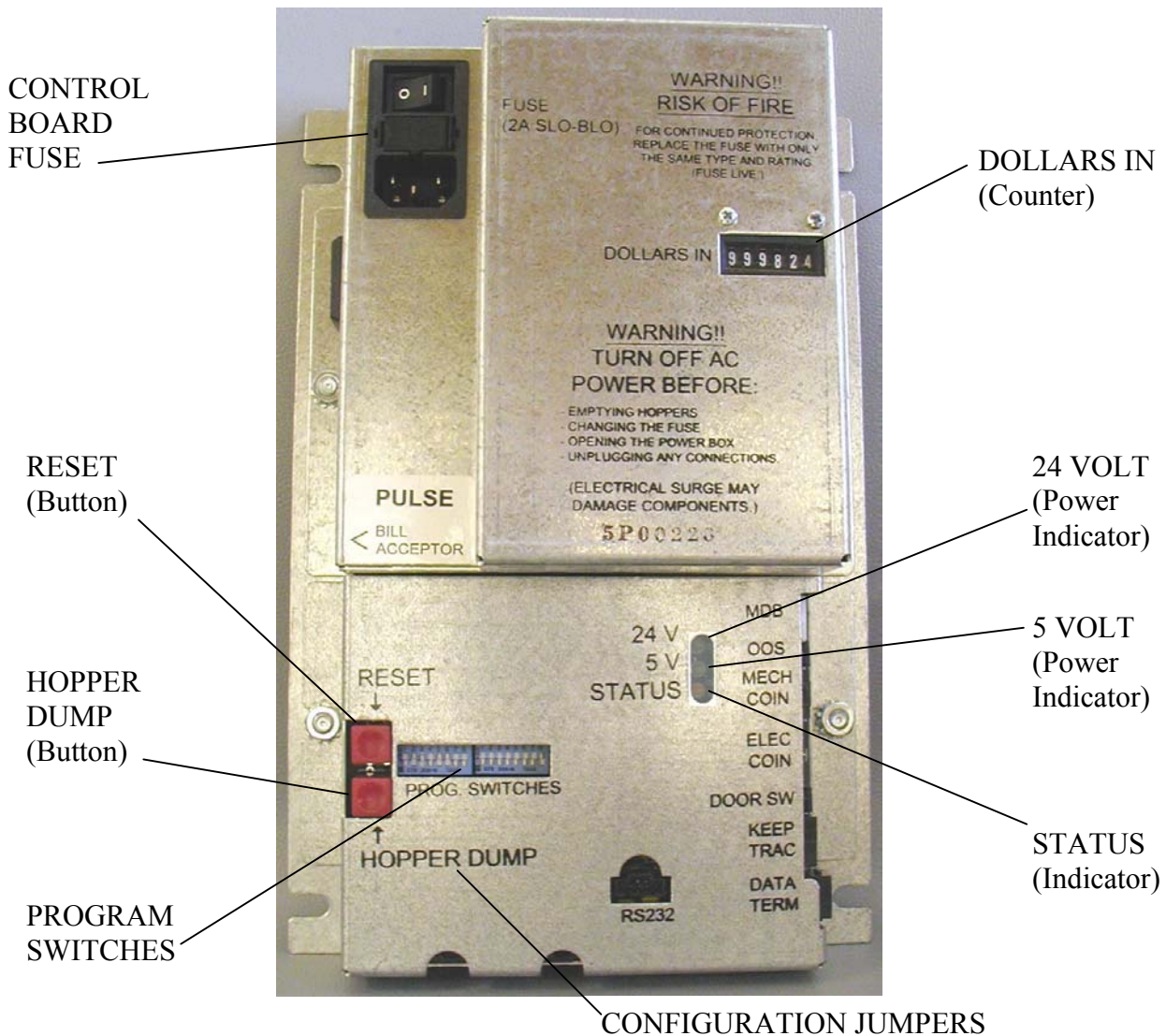

## 7.2 Control Board Fuse

The primary AC fuse for both the controller board and the connected bill acceptor is located in the fuse holder next to the power switch. **Be sure to disconnect AC power to the changer before changing the fuse.** Replace it with a 2-ampere 250V slow blow fuse.

## 7.3 Status Indicator and Error Codes

The status indicator provides an indication of the condition of the machine. The possible

- Steady flashing – normal operation.
- Steady on – Out of service.
- Intermittent flashing – Error condition, see flash code table below for details. Count the number of times the led flashes (between long off periods) to determine the flash code number. Use the table to isolate the source of the error condition.

Flash Code Table (number of times LED flashes)

Flash Code	Problem	Flash Code	Problem
1	Illogical switch settings or switch settings not supported	9	Bill acceptor error <sup>1</sup>
2	Sold out dispenser B	10	Error dispenser B <sup>1</sup>
3	Sold out dispenser A	11	Error dispenser A <sup>1</sup>
4	Sold out both dispensers	12	Error both dispensers <sup>1</sup>
5	Bill/Card Dispenser output blocked	13	Fast Vend shut off <sup>1</sup>
6	No payout dispenser B <sup>1</sup>	14	Overpay <sup>1</sup>
7	No payout dispenser A <sup>1</sup>	15	Short Vend (possible incorrect bill pulses)
8	No payout both dispensers <sup>1</sup>	16	Power loss during dispense

1 – System control board must be reset if one of these errors occurs.

### Important Notes:

- The System control board must be reset after the error condition is corrected. Always test the machine before placing back into service.
- The System Controller can only store and display one error at a time.
- Removing the bill box from the bill acceptor will cause a bill acceptor error when using some manufacture's acceptors. Press the reset button after reinstalling the bill box to clear the error.

## 7.4 5V and 24V Power Indicators

The 24V (Main Power) Indicator is on steady if the 24vdc supply is functioning properly. The 5V (Logic Power) Indicator is on steady if the 5vdc is functioning properly. If either of these indicators are off, review the troubleshooting section of this manual.

## 7.5 Reset Button

To reset the system control board to a known state you must first resolve the issue that caused the error condition. Once this is completed, press and release the button labeled "RESET".

## 7.6 Dump Hopper Button

This button is used to empty the few coins that remain in the coin hopper after it has sensed an empty condition. The coin hopper **MUST** be in the sold out condition before it can be completely emptied using this button. To activate, press and release this button then wait for 5-seconds. The dispenser will begin to rotate after the 5-second delay and all remaining coins will be dispensed. The coin dispenser will stop when all coins have been cleared.

## 7.7 Dollars In Counter

This non-resettable counter indicates the total number of dollars accepted by the changer. One count equals one dollar deposited in the machine. Amounts less than one dollar are not indicated until one dollar is reached. Example: if three quarters are deposited the counter is not updated. If a fourth quarter is deposited, the counter is incremented by one.

## 7.8 Program Switches

The basic operating modes and functional parameters of the machine can be easily reconfigured using the Program Switches. The program switches are used to set a particular mode of operation (data terminal mode, changer mode, token mode...) or to set a functional parameter of the machine such as the value of a particular dispenser, the amount to be accumulated, the management of money held in escrow, or the amount to be force vended from a dispenser. For a detailed explanation and a list of switch settings for each operating mode and machine parameter, read the remainder of this section.

**Important Notes** regarding the DIP switches.

- Use a small pointed object to move the switches to either ON or OFF position as needed.
- Always cycle power off then on after changing the DIP switch settings.
- A flash code error will be displayed if the option switches have been set to perform an illogical or non-used state. See the paragraph (this section) regarding “System Control Board Indicator Lights” for this flash code.

## 7.9 Configuration Jumpers

These jumpers are for factory settings only. They should not be altered unless the machine hardware is being reconfigured to include or eliminate a device listed below. The EC+ Controller cover must be removed to access these jumpers.

- JP3 – Hopper Transfer Disable (EC+ Controller Only) With this jumper installed, the automatic hopper transfer on error feature will be turned off. To turn this off on a premium controller use the data terminal setup menu.
- JP4 – Card Dispenser Configuration. If your machine is equipped with a card dispenser, a small jumper block (two pin blue jumper) must be installed on the two pins labeled JP4 on the Configuration Jumper block section of the control board.
- JP5 – Bill Dispenser Configuration. If your machine is equipped with a bill dispenser, a small jumper block (two pin blue jumper) must be installed on the two pins labeled JP5 on the Configuration Jumper block section of the control board.
- JP10 – Mars bill acceptor (pulse only) Configuration. Without this jumper installed, the Mars bill acceptor will go through a reset cycle after a bill has been accepted. This reset cycle will cause a short delay between bill insertions.

## 7.10 Understanding The Machine “Operating Modes”

There are four program modes available that can be used to alter and enhance the machine functionality. A brief description of each mode is outlined below. It is **extremely important that you understand and choose the correct operating mode** since the remaining option switches have a different purpose for each of the operating modes.

- **DATA TERMINAL MODE** – Allows the machine operating modes to be set by the data terminal. Notes: For this mode a data terminal must be present. If this mode is used, see the Data Terminal manual for setting available machine options.
- **BILL/COIN MODE** – This mode is used if the machine dispenses coins (not tokens) and / or bills. This is the most commonly used mode of operation in machines that vend money for money deposited. In this mode the machine will automatically determine the *least number of coins* (or bills) needed to make change for a given deposit. In machines that include multiple dispensers, this operating mode can be further modified to force a preset number of coins (or bills) to be vended from one dispenser before determining the least number required to complete the remaining vend. For more information about this mode see the section 7.12 *Bill/Coin Mode*.
- **TOKEN MODE** – This mode is used when dispensing tokens and when bonus token amounts are to be vended. For more information about this mode see the section 6.13 *Token Mode*.
- **FORCED DISPENSE OVERRIDE MODE** – This mode is the same as the Bill/Coin Mode with the exception of certain deposit / dispenser value conditions. It is sometimes desirable to vend a coin of the same value as the bill deposited as opposed to breaking the deposited bill down in to smaller valued coins. An example of this condition is when a one-dollar bill is deposited and a dollar coin is to be vended. If this mode is not set the machine would automatically dispense quarters instead of a dollar coin.

See the remaining sections regarding Program Switches and Setting the Operating Mode to determine how to make changes to the factory configuration of your machine.

## 7.11 Setting The Machine “Operating Mode”

The machine-operating mode is set using the three DIP switches located on the right hand end of available switches. For exact position of these three switches and the proper setting for each operating mode, see the table and diagram below.

MODE TABLE	6	7	8
0 – Data Terminal Mode	Off	Off	Off
1 – Bill/Coin Mode	Off	Off	On
2 – Token Mode	Off	On	Off
3 – Forced Dispense Override Mode	Off	On	On

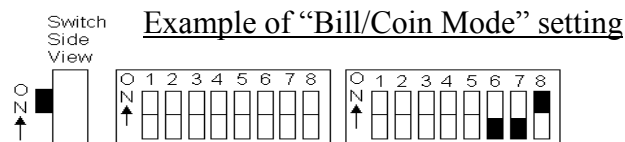

## 7.12 Bill/Coin Mode

A variety of functional parameters can be set in conjunction with the Bill/Coin Mode. This section provides a brief description of each parameter and shows how they can be set using the Programming Switches. Below is a diagram showing how the program switches would be set to manage the functional parameters in a simple change machine.

### 7.12.1 Programming Mode 1 Switch Diagram

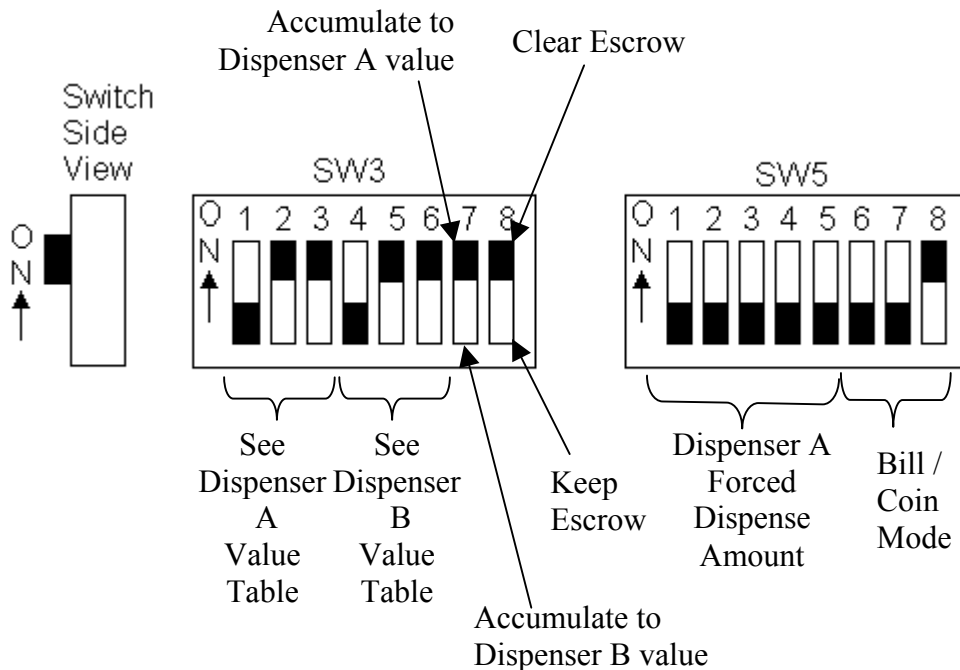

### 7.12.2 Setting the Dispensers Value

Each Dispenser must be valued so that the system control board will know how many coins or bills to issue for each bill or coin accepted. If only one dispenser is to be used, locate this dispenser in position A and set the dispenser B value to inactive. Set the program switches to the desired dispenser value using the following tables. See the programming notes for special cases and additional information.

Important notes regarding machines with Bill Dispensers or Card Dispensers:

- The Bill Dispenser must always be plugged into hopper position B on the system controller, even if it is the only dispenser used.
- Use the Bill Dispenser Value Table in place of the Dispenser B Value Table for setting the dispense value.
- The Card Dispenser must always be plugged into hopper position A on the system controller, even if it is the only dispenser used.
- Use the Card Dispenser Value Table in place of the Dispenser A Value Table for setting the dispense value.
- EC+ Controller must be configured for Bill/Card Dispenser (See section 7.9).



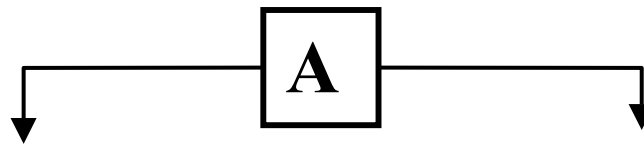

**COINS DISPENSED**  
Dispenser A Value Table

Value	SW3 Switch		
	1	2	3
Dispenser Inactive	Off	Off	Off
\$.05	Off	Off	On
\$.10	Off	On	Off
\$.25	Off	On	On
\$1.00	On	Off	Off
\$2.00	On	Off	On

**CARDS DISPENSED**  
Dispenser A Value Table

Value	SW3 Switch		
	1	2	3
Dispenser inactive	Off	Off	Off
\$1.00	Off	Off	On
\$2.00	Off	On	Off
\$5.00	Off	On	On
\$10.00	On	Off	Off
\$20.00	On	Off	On
\$50.00	On	On	Off
\$100.00	On	On	On

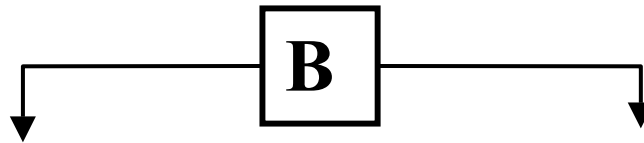

**COINS DISPENSED**  
Dispenser B Value Table

Value	SW3 Switch		
	4	5	6
Dispenser Inactive	Off	Off	Off
\$.05	Off	Off	On
\$.10	Off	On	Off
\$.25	Off	On	On
\$1.00	On	Off	Off
\$2.00	On	Off	On

**BILLS DISPENSED**  
Dispenser B Value Table

Value	SW3 Switch		
	4	5	6
Dispenser inactive	Off	Off	Off
\$1.00*	Off	Off	On
\$2.00	Off	On	Off
\$5.00	Off	On	On
\$10.00	On	Off	Off
\$20.00	On	Off	On
\$50.00	On	On	Off
\$100.00	On	On	On

**\*Dispensing \$1.00 bills is not recommended due to the general condition of the circulated bills.**

**Important notes** regarding dispenser values:

- The System Controller will report an illogical programming error if in a single dispenser machine or a dual dispenser machine all dispenser values are set to \$2.00, this is because it will not be possible to give correct change for a five dollar bill.
- The maximum payout from any one dispenser is 200 coins. This is done to limit the amount of coins dispensed if a system failure occurred.
- Dispenser A Value table (Cards) is determined by configuration jumper JP4. See section 6.9 for more information.
- Dispenser B Value table (Coins or Bills) is determined by configuration jumper JP5. See section 6.9 for more information.

### 7.12.3 Setting the Dispenser Vend Amounts

If the same value item is dispensed from the A and B dispensers, and you want the machine to distribute change from each dispenser equally, do not set the Forced Dispense condition. The machine will automatically determine the necessary payout from each dispenser.

Example: Dispenser A and B are both dispensing quarters. For a \$5 deposit 10 quarters would be dispensed from hopper A and 10 from hopper B. For a \$10 deposit 20 quarters would be dispensed from hopper A and 20 from hopper B and so on.

Your machine is equipped with an automatic transfer feature. If one of the two available dispensers cannot complete a vend for any reason, the remaining dispense amount is automatically transferred to the other dispenser. This will continue until the second dispenser becomes empty. You can also force one of the two dispensers to vend a certain amount before the most efficient payout is determined.

#### 7.12.3.1 Forced Dispense Condition

If different valued coins are to be dispensed from dispenser A and B, the switches labeled “Dispenser A forced dispense amount” can be used to force a given number of coins to be dispensed from Dispenser A. The remaining balance for the bill deposited will then be dispensed in the most efficient payout available (least number of coins, cards or bills).

See the following table to set the dispenser A forced dispense amount.

**NOTE:** If box is blank switch is OFF.

Dispenser A Dispense amount	SW5 Switch				
	1	2	3	4	5
0					
1					On
2				On	
3				On	On
4			On		
5			On		On
6			On	On	
7			On	On	On
8		On			
9		On			On
10		On		On	
11		On		On	On
12		On	On		
13		On	On		On
14		On	On	On	
15		On	On	On	On

Dispenser A Dispense amount	SW5 Switch				
	1	2	3	4	5
16	On				
17	On				On
18	On			On	
19	On			On	On
20	On		On		
21	On		On		On
22	On		On	On	
23	On		On	On	On
24	On	On			
25	On	On			On
26	On	On		On	
27	On	On		On	On
28	On	On	On		
29	On	On	On		On
30	On	On	On	On	
31	On	On	On	On	on

### **Example 1:**

Dispenser value settings:

- Dispenser A = \$.05
- Dispenser B = \$.25

Dispenser A forced dispense amount set to 5. (SW5 position 3 and 5 = ON)

\$1 accepted: Payout is 5 from dispenser A and 3 from dispenser B

\$5 accepted: Payout is 5 from dispenser A and 19 from dispenser B

\$.25 accepted: Payout is 5 from dispenser A and 0 from dispenser B

Notes: If the dispenser A dispense amount is set to zero the system controller will calculate the most efficient dispense amount (least number of coins) by vending as many of the highest valued coins, then vend the remaining balance from the lower valued dispenser.

### **Example 2: Coin and Bill Dispense (BCX1000)**

Dispenser value settings:

- Dispenser A = \$1.00 (Coin)
- Dispenser B = \$5.00 (Bill)

Forced dispense amount set to 5. (SW5 position 3 and 5 = ON)

\$1 acceptance: Turned Off

\$5 accepted: Payout is 5 from dispenser A and 0 from dispenser B

\$10 accepted: Payout is 5 from dispenser A and 1 from dispenser B

\$20 accepted: Payout is 5 from dispenser A and 3 from dispenser B

#### **7.12.4 Setting the Accumulate Value**

The accumulate value allows the machine to continue to hold deposits until a preprogrammed value (accumulate value) is reached. This feature is most commonly used when coins are being accepted. For example in a machine with one quarter valued hopper: if a dime is deposited nothing can be dispensed since a dime is not enough to start a vend. The machine will hold the dime until another 15 cents has been deposited, at which time it will vend 1 quarter for the 25 cents deposited.

The accumulate value is equal to the hopper value, or in the case of a two hopper machine it is equal to only one of the hopper values. The hopper to be used is determined by the switch setting.

SW3 Switch 7

ON – Accumulate value will be dispenser A's value

OFF – Accumulate value will be dispenser B's value

EXAMPLE: Dispenser A value is set to \$.25, dispenser B value is set to \$.05, and the accumulate amount is set to equal dispenser A value. When the customer inserts a nickel and two dimes, one quarter will be paid out of dispenser A. If three dimes are inserted payout will be 1 from dispenser A and 1 from dispenser B.

### 7.12.5 Escrow

Escrow is any amount still owed to the customer after a dispense is completed. This only applies to a transaction where the amount still owed does not equal at least the value of either dispenser. This amount can be kept and applied to the value of the next transaction, or the change machine can clear and retain it after every coin dispenses. See the following to set the Escrow.

#### SW3 Switch 8

ON – Clear escrow amount from memory (overage is kept)

OFF – Keep the escrow amount in memory (overage is applied to the value of the next transaction)

EXAMPLE: Dispenser A value is set to \$.25 and dispenser B value is set to \$.25. The patron inserts three dimes. One quarter is paid out of dispenser A. Since the patron inserted thirty cents the machine still owes them a nickel. The nickel is considered the escrow amount.

## 7.13 Token Mode

### 7.13.1 Programming Mode 2 Switch Diagram

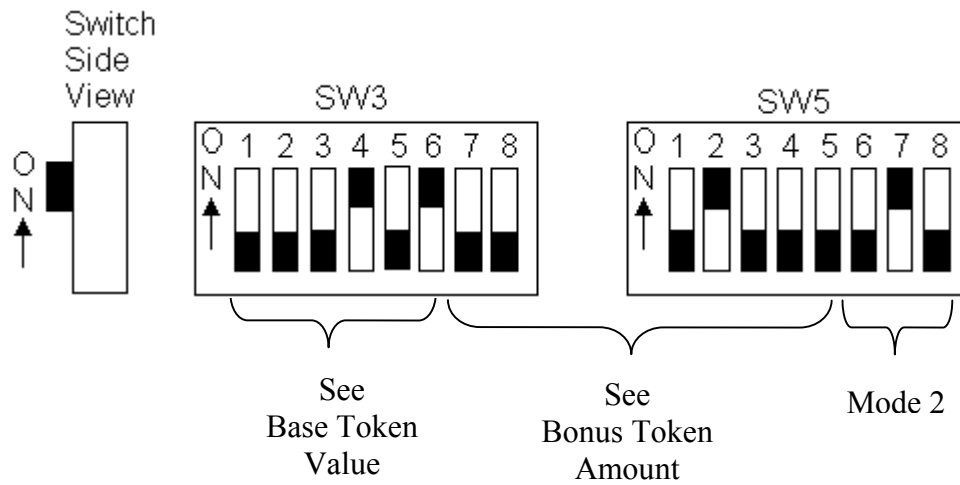

### 7.13.2 Setting the Base Token Value

Use SW3 Switches 1-6 to set the base token value. (See Base Token Value Table) This is the value of a token. Bonus tokens are not considered during this step. In other words, if you sell one single token for twenty-five cents, the base value of the token is twenty-five cents. The extra tokens issued for larger bills are considered “Bonus” tokens.

When the Base Token Value is reached or exceeded, a payout will occur. Any money remaining after a dispense will be left in escrow for the next dispense. Escrow is any amount still owed to the customer after a dispense is completed. This only applies to a transaction where the amount still owed does not equal the base token value.

### 7.13.3 Setting the Bonus Token Amount

Use SW3 switches 7,8 and SW5 switches 1-5 to set the Bonus Token Amount. Bonus tokens are extra tokens paid for inserting larger denomination bills. To set the number of bonus tokens to be issued for each bill, find the desired amount in the bonus table and set the appropriate switches.

### 7.13.4 Base Token Value Table

**NOTE:** If a box is blank the switch setting is OFF

This table lists the most common settings. See Appendix H for other token values.

Value	SW3					
	1	2	3	4	5	6
Dispenser Inactive						
\$.05						On
\$.10					On	
\$.25				On		On
\$.50			On		On	
\$1.00		On		On		
\$2.00	On		On			

### 7.13.5 Bonus Token Amount Table

This table lists the most common settings. See Appendix I for other bonus dispense amounts.

**NOTE:** If box is blank switch setting is OFF

Bonus Dispense amount for:					SW3		SW5				
\$1	\$2	\$5	\$10	\$20	7	8	1	2	3	4	5
0	0	0	0	0							
0	0	0	0	10							On
0	0	0	5	10				On			
0	0	0	5	20				On			On
0	0	1	2	5				On		On	On
0	0	1	3	6				On	On		On
0	0	1	5	12			On			On	On
0	0	3	7	15			On		On		
0	0	5	8	10			On		On		On
0	0	5	20	40			On		On	On	
0	1	1	6	11			On		On	On	On
0	1	2	4	8			On	On			

EXAMPLE: See Section 6.13.2

Base Token value equals \$.25 (SW3 position 4 and 6 On)

Bonus Token amount equals 5 extra for \$10 and 10 extra for \$20 (SW5 position 2 On)

## 7.14 Forced Dispense Override Mode

### 7.14.1 Programming Mode 3 Switch Diagram

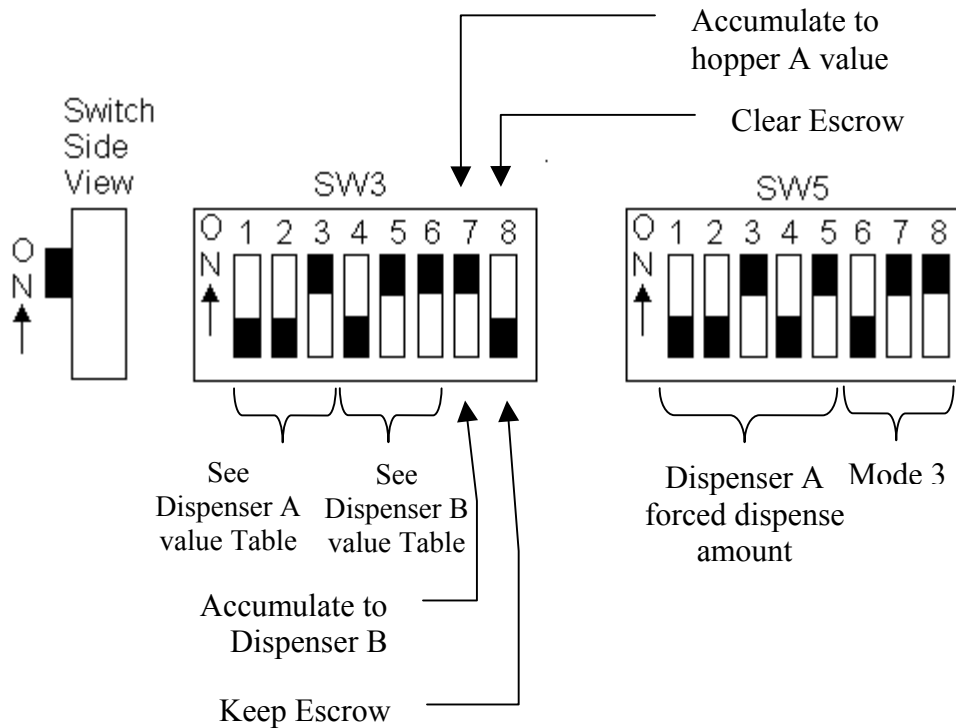

### 7.14.2 Setting the Dispenser Value

This mode is essentially the same as Mode 1. The only exception is that the value of the bill or coin is compared to the values of both dispensers. If that value matches a dispenser value a dispense is made from that dispenser. In this way the dispenser value overrides the forced dispense amount.

Example:

Dispenser value settings:

- Dispenser A = \$.05
- Dispenser B = \$1.00
- Forced Dispense = 20

\$1 accepted: payout is 0 from dispenser A and 1 from dispenser B.

\$5 accepted: payout is 20 from dispenser A and 4 from dispenser B.

\$.25 accepted: payout is 5 from dispenser A and 0 from dispenser B.

## 7.15 Optional Setup Mode – Functional Parameters

### 7.15.1 Option mode 6 switch diagram

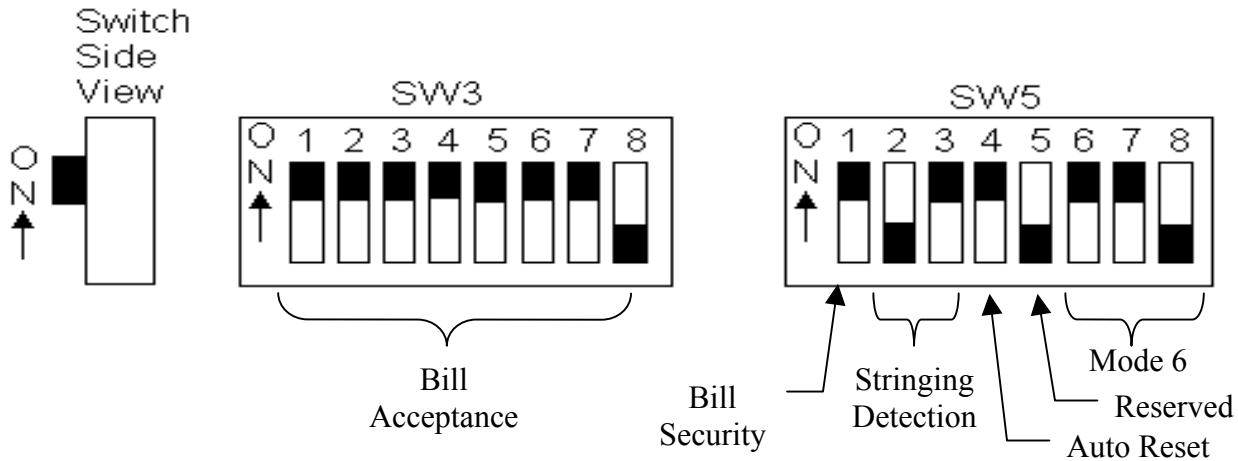

**\*\* VERY IMPORTANT \*\***

Note (write down) the current setting for all of the programming switches before changing these settings. These features are set by temporarily using these switches. Upon completion of setting these parameters, the switches will need to be returned to their original positions.

**NOTE: SW5-switch 5 should always be set to the OFF position when making changes.**

Press the reset button to enter (or activate) the switch selections. Once you have entered (or activated) this mode, you must return the programming switches back to the desired Machine Operating Mode and press the reset button to return the machine to its normal operating mode.

### 7.15.2 Bill Acceptance Settings

This feature will allow you to choose which bill denomination to accept or reject when using MDB note acceptors that may not have this option available within the manufacturer's procedure. This will also allow you to change the acceptance without special cards or equipment in the field. To enable acceptance of a bill denomination move the corresponding switch to the ON position. To disable acceptance of a bill denomination move the corresponding switch to the OFF position.

For US and Canadian note acceptors, the following switch table would apply.

Switch SW3	1	2	3	4	5	6	7	8
Bill value	\$1*	\$2*	\$5	\$10	\$20	\$50	\$10	NA
							0	

\* US ONLY

NOTE: These switches will only adjust the acceptance for bills that have been already enabled in the note acceptor using the manufacturers procedure. See note acceptor manufactures documentation for instructions on how to enable bills at the note acceptor.



### 7.15.3 Bill Security Settings

Bill security on some MDB note acceptors models can be set to high or low in order to obtain the desired validation security. If the note acceptor supplied with your machine has the high / low security feature, SW5 - switch 1 can be used to set this level. To set bill security to high, move switch 1 to the ON position. To set the security to low, move switch 1 to the OFF position. See you note acceptor documentation for information on how this changes bill acceptance in you unit

### 7.15.4 Stringing Detection Settings

MDB validators have the ability to recognize possible stringing attempts. A stringing attempt is when someone tries to remove a bill from the validator by using tape or wires after it has been accepted and reported to the controller. This setting will change the when a stringing attempt is detected by the system controller. There are three levels of detection for this, see explanation of each below.

Table for switches settings.

Switch SW5	2	3
LOW	OFF	OFF
MEDIUM	OFF	ON
HIGH	ON	ON

**LOW** – The system controller will not respond (go out of service) to any “tampering” signals issued by the bill acceptor. Note: this setting may be necessary to reduce or eliminate false tamper signals that occur in some bill acceptor models when a bill is inserted while a previous bill is being rejected. Caution – this will reduce the machines ability to detect actual stringing.

**MEDIUM** – The System Controller will ignore “tampering” signals that may indicate possible a stringing attempt only when there are no credits. If there are credits or a payout is in progress, the changer will shut down with a note acceptor error (flash code 9). No further transactions will occur until the machine is reset either manually or with the Auto Reset feature.

**HIGH** - The System Controller take the machine to go out of service if the note acceptor issues any “tampering” signals. The changer will shut down with a bill acceptor error (flash code 9). No further transactions will occur until the machine is reset either manually or with the Auto Reset feature. False errors may occur if bills are rapidly fed into the machine.

### 7.15.5 Auto Reset Setting

The Auto Reset feature will attempt to automatically reset the machine from an out of service condition after a preset time. Errors that can be auto reset are: Note Acceptor errors (flash code 9) and Fast Vend errors (flash code 13). SW5 - switch 4 can be used to enable or disable the auto-reset feature. To enable auto reset, move switch 4 to the ON position. To disable auto reset, move switch 4 to the OFF position. The default auto reset time will be 10 minutes if the Fast Vend time setting has not been programmed or will be the Fast Vend time if programmed. Example: Fast Vend Time = 20min (The auto reset attempt will occur 20min after a Fast Vend or Note Acceptor error).

#### **IMPORTANT NOTE:**

The default factory settings for these features are:

Bills accepted = ALL

Security = HIGH

Stringing Detection = MEDIUM

Auto Reset = ON

**NOTE: SW5-switch 5 should always be set to the OFF position when making changes.**

### 7.16 Fast Vend Shut Off Feature

This feature provides additional security against theft by identifying unusual deposit patterns. In other words, if more money than normal is coming into the machine this feature can detect it and protect the machine by automatically taking it off-line. The unusual pattern is based on a maximum number (programmed) of any denomination bill deposited in a given (programmed) time frame. Once exceeded, the machine will go out of service with the status led indicating a flash code 13.

Example: The machine is set to take a maximum of ten \$5.00 bills in 20 minutes. If eleven \$5.00 bill's are accepted in less than twenty minutes the machine will automatically go out of service, retain the last bill inserted, finish the payout and display the fast vend flash code on the status led.

**Important Notes** regarding the Fast Vend Shut Off Feature:

- The factory setting for this feature is = Disabled.
- The Fast Vend condition can be reset (machine back into service) by pressing the reset button.
- The settings for this feature should be based on the machines highest normal volume usage.

### 7.16.1 Switch Diagram

Use the following tables and diagrams to determine the optimum setting for your machines normal deposit volume (bills deposited).

**\*\* VERY IMPORTANT \*\***

Note (write down) the current setting for all of the programming switches. The fast vend feature is set by temporarily using these switches. Upon completion of setting the fast vend feature parameters, these switches will be returned to their original positions.

Press the reset button to enter (or activate) the switch selection. Once you have entered (or activated) this mode, you must return the programming switches back to the desired Machine Operating Mode.

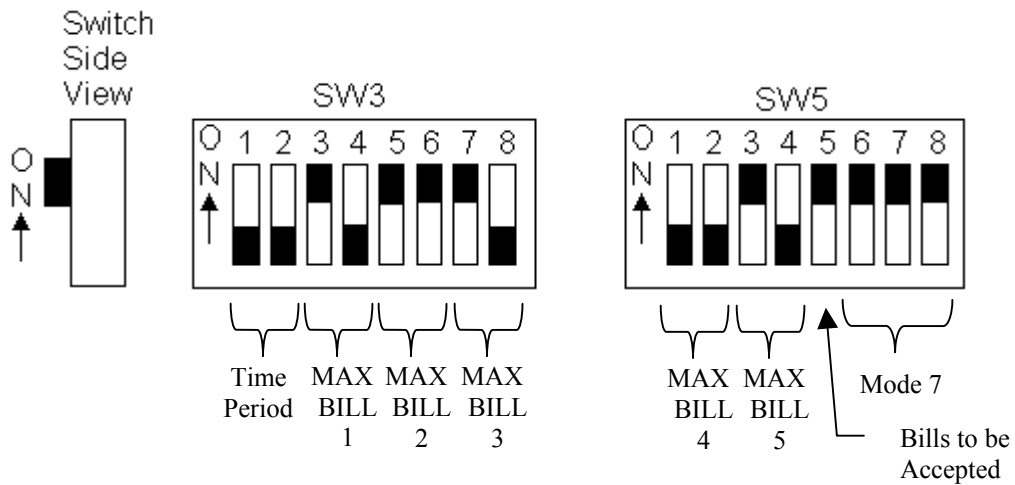

### FAST VEND DEFAULT SETTINGS

The default factory fast vend settings are:

Fast Vend Time 20 minutes

Bill Value	\$1	\$2	\$5	\$10	\$20	\$50	\$100
Bill Count	60	60	20	15	10	10	5

### 7.16.2 Switch Settings When Accepting Bills \$1-\$20

#### SW3 SWITCH SETTINGS

TIME PERIOD			MAX BILLS PER TIME PERIOD			MAX BILLS PER TIME PERIOD			MAX BILLS PER TIME PERIOD		
1	2	PERIOD	3	4	PERIOD	5	6	PERIOD	7	8	PERIOD
<b>TIME SETTINGS</b>			<b>1's</b>			<b>\$2</b>			<b>\$5</b>		
OFF	OFF	Disabled	OFF	OFF	disabled	OFF	OFF	Disabled	OFF	OFF	disabled
OFF	ON	20 minutes	OFF	ON	30	OFF	ON	30	OFF	ON	5
ON	OFF	30 minutes	ON	OFF	45	ON	OFF	45	ON	OFF	10
ON	ON	60 minutes	ON	ON	60	ON	ON	60	ON	ON	20

#### SW5 SWITCH SETTINGS

MAX BILLS PER TIME PERIOD			MAX BILLS PER TIME PERIOD			BILLS TO BE ACCEPTED		CONTROLLER MODE			
1	2	PERIOD	3	4	PERIOD	5	6	7	8	MODE	MODE
<b>\$10</b>			<b>\$20</b>			<b>BILLS</b>		<b>MODE</b>			
OFF	OFF	Disabled	OFF	OFF	Disabled	OFF	\$1- \$20	ON	ON	ON	7
OFF	ON	3	OFF	ON	2			ON	ON	ON	7
ON	OFF	10	ON	OFF	5			ON	ON	ON	7
ON	ON	15	ON	ON	10			ON	ON	ON	7

### 7.16.3 Switch Settings When Accepting Bills \$5-\$100

#### SW3 SWITCH SETTINGS

TIME PERIOD			MAX BILLS PER TIME PERIOD			MAX BILLS PER TIME PERIOD			MAX BILLS PER TIME PERIOD		
1	2	PERIOD	3	4	PERIOD	5	6	PERIOD	7	8	PERIOD
<b>TIME SETTINGS</b>			<b>\$5</b>			<b>\$10</b>			<b>\$20</b>		
OFF	OFF	Disabled	OFF	OFF	Disabled	OFF	OFF	disabled	OFF	OFF	disabled
OFF	ON	20 minutes	OFF	ON	5	OFF	ON	3	OFF	ON	2
ON	OFF	30 minutes	ON	OFF	10	ON	OFF	10	ON	OFF	5
ON	ON	60 minutes	ON	ON	20	ON	ON	15	ON	ON	10

#### SW5 SWITCH SETTINGS

MAX BILLS PER TIME PERIOD			MAX BILLS PER TIME PERIOD			BILLS TO BE ACCEPTED		CONTROLLER MODE			
1	2	PERIOD	3	4	PERIOD	5	6	7	8	MODE	MODE
<b>\$50</b>			<b>\$100</b>			<b>BILLS</b>		<b>MODE</b>			
OFF	OFF	Disabled	OFF	OFF	disabled	ON	\$5-\$100	ON	ON	ON	7
OFF	ON	2	OFF	ON	2			ON	ON	ON	7
ON	OFF	5	ON	OFF	4			ON	ON	ON	7
ON	ON	10	ON	ON	5			ON	ON	ON	7

## 8.0 Bill Acceptors

The EC+ Machine Series is able to use most OEM style 110VAC pulse type bill acceptors and most OEM style Multi-drop Bus (MDB) bill acceptors.

The pinouts for the cables supplied with EC+ Machine Series changers are listed in Appendix J.

### 8.1 Pulse Bill Acceptors

The following is list of Pulse Bill Acceptors that will work in the EC+ Machine Series:

**Note:** Some of these acceptors require power converters to work properly. Contact the bill acceptor manufacturer for a 110 VAC power converter.

Coinco BA30B  
MAG50B

Cash Code AMZ-USA-1100-UNV\*  
AMZ-CAN-2100-UNV\*

Mars  
VN2300  
VN2500  
AE2400  
AE2600  
AL4 series\*  
GL4 series\*  
GL5 series\*  
L005\*  
VFM-1\*  
VFM-2\*  
VFM-3\*  
VFM-4\*  
VFM-5S\*

Maka NB-10\*  
NB/NBE-20\*

Dixie-Narco USA-15\*

### 8.2 Additional Bill Acceptor Information

\* NOTE: These bill acceptors may require an optional universal interface cable kit SCM P/N 4K00304. The kit includes a multiplug cable and an 18-pin interface plug.

## 8.2.1 Coinco BA30 Information

To interface to the Coinco BA30 acceptor, the following setting should be used for the “\$1 = one Pulse” configuration. See the acceptor manual for full details. This acceptor requires the cable SCM P/N 4C00224. The DIP switch settings should be:

### 8-Position Switch

1	On
2	Off
3	On
4	On
5	On
6	On
7	Off
8	On

### 8.2.1.1 EC100 Installation

Note: On the EC100 model ONLY, the external CPU on the Coinco BA30B must be moved forward to allow the door to close properly. To do this first remove the three screws from the backside of the verifier holding the external CPU assembly on (step1). Next, reposition the external CPU assembly to the front side of the mounting holes and install the screws from the front side of the acceptor (step2). The Verifier can then be properly mounted to the cabinet door.

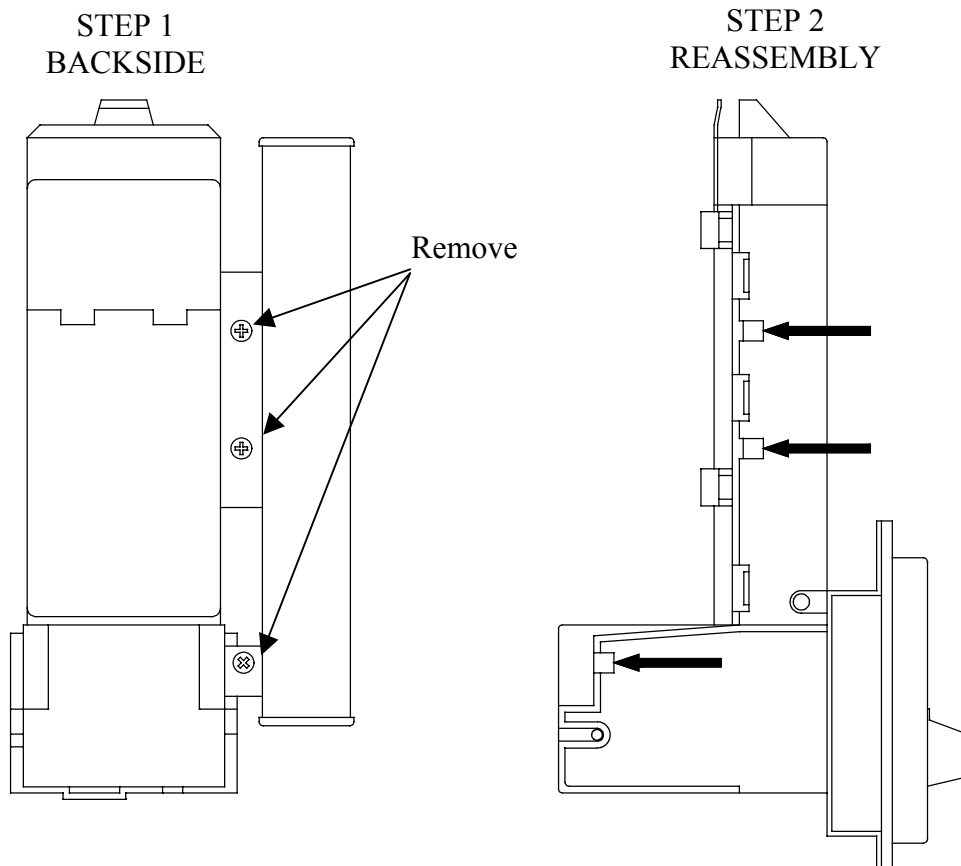

## 8.2.2 Cash Code Brand Bill Acceptor Information

To interface to the Cash Code AMZ-USA-1100-UNV or the AMZ-CAN-2100-UNV acceptors, the following setting should be used for the "\$1 = one Pulse" configuration. See the acceptor manual for full details. This verifier requires the cable SCM P/N 4C00230. The DIP switch settings should be:

<u>8-Position Switch</u>		<u>4-Position Switch</u>	
1	On	1	Off
2	On	2	Off
3	On	3	Off
4	On	4	Off
5	Off		
6	On		
7	Off		
8	On		

Use the 4K00353 installation kit for the EC100, EC300RL and EC500RL.

Use the 4K00354 installation kit for the EC200 and EC400RL.

This verifier requires the cable SCM P/N 4C00230.

Also, specify a 600 or 1000 bill stacker for when ordering this verifier.

## 8.2.3 MARS Series 2000 Bill Acceptors

VN2300

VN2500

AE2400

AE2600

All units require the 110Vac interface

**The VN2300 and VN2500 require a special 18-pin interface jumper plug MARS P/N250074011 this part is not included with the acceptor or the changer.**

To interface to the MARS acceptors see the appropriate switch settings below. Switch settings are for \$1 = one pulse configuration. See acceptor manuals for full details on switch settings.

<u>VN2300</u> <u>8-Position</u> <u>Switch</u>	<u>VN2500</u> <u>8-Position</u> <u>Switch</u>	<u>AE2400</u> <u>8-Position</u> <u>Switch</u>	<u>AE2600</u> <u>8-Position</u> <u>Switch</u>
1 Off	1 Off	1 Off	1 Off
2 On	2 On	2 On	2 On
3 On	3 On	3 On	3 On
4 On	4 On	4 On	4 On
5 Off	5 Off	5 Off	5 Off
6 Off	6 On	6 On	6 On
7 On	7 On	7 Off	7 Off
8 Off	8 Off	8 Off	8 On

## 8.2.4 Mars AL4 and GL4 Bill Acceptor Information

To interface to the MARS AL4 or GL4 acceptors the following setting should be used for the “\$1 = one Pulse” configuration. See the acceptor manual for full details. Requires optional universal interface cable kit SCM P/N 4K00304. The DIP switch settings should be:

<u>8-Position Switch</u>		<u>4-Position Switch</u>	
1	On	1	Off
2	On	2	Off
3	On	3	Off
4	On	4	Off
5	On		
6	Off		
7	On		
8	On		

## 8.2.5 Mars VFM-1 Bill Acceptor Information

To interface to the MARS VFM-1 acceptors the following setting should be used for the “\$1 = one Pulse” configuration. See the acceptor manual for full details. Requires optional universal interface cable kit SCM P/N 4K00304. The DIP switch settings should be:

### 2-Position Switch

1	Off
2	On

The 18-pin interface jumper plug should not be used.

The VFM-1 acceptor has different AC connections than other acceptors. To make it work the white/green neutral wire connected to pin 1 of the 9-pin connector must be cut. The top row of the connector consists of pins 1,2,and 3; the numbers are marked on the back of the connector. The wire colors are white/green, white/green, and white. **TURN POWER OFF BEFORE CUTTING THE WIRING.** The outlet might be wired reversed and the wire is actually hot. Cut the wire to pin 1 in the middle. That way the wire can be joined again if needed in the future. Put the supplied wire-nuts on cut ends of the wire to prevent them from shorting.



### 8.2.6 Mars VFM-2 Bill Acceptor Information

To interface to the VFM-2 acceptor the following setting should be used for the “\$1 = one Pulse” configuration. See the acceptor manual for full details. Requires optional universal interface cable kit SCM P/N 4K00304. The DIP switch settings should be:

#### 8-Position Switch

1	On
2	Off
3	On
4	Off
5	Off
6	Off
7	Off
8	Off

The 18-pin interface jumper plug should have all of the **BLACK** wires cut.

### 8.2.7 Mars VFM-3 and L005 Bill Acceptor Information

To interface to the VFM-3 or the L005 acceptor the following setting should be used for the “\$1 = one Pulse” configuration. See the acceptor manual for full details. Requires optional universal interface cable kit SCM P/N 4K00304. The DIP switch settings should be:

#### 8-Position Switch

1	Off
2	Off
3	Off
4	Off
5	Off
6	On
7	On
8	Off

The 18-pin interface jumper plug should have all of the **BLACK** wires cut and the **RED** wire cut.

### 8.2.8 Mars VFM-4 Bill Acceptor Information

To interface to the VFM-4 acceptor the following setting should be used for the “\$1 = one Pulse” configuration. See the acceptor manual for full details. Requires optional universal interface cable kit SCM P/N 4K00304. The DIP switch settings should be:

#### 8-Position Switch

1	On
2	Off
3	On
4	On
5	On
6	Off
7	Off
8	Off

The 18-pin interface jumper plug should have all of the **BLACK** wires cut.

### 8.2.9 Maka NB-10 Bill Acceptor Information

To interface to the Maka NB-10 acceptor the following setting should be used for the “\$1 = one Pulse” configuration. Requires optional universal interface cable kit SCM P/N 4K00304. See the acceptor manual for full details.

The 18-pin interface jumper plug should not be used.

### 8.2.10 Maka NB/NBE-20 Bill Acceptor Information

To interface to the Maka NB/NBE-20 acceptor the following setting should be used for the “\$1 = one Pulse” configuration. See the acceptor manual for full details. Requires optional universal interface cable kit SCM P/N 4K00304. The DIP switch settings should be:

#### 6-Position Switch

1	On
2	On
3	Off
4	Off
5	Off
6	Off

The 18-pin interface jumper plug should have the **RED** wire cut.

### 8.2.11 Dixie-Narco USA-15 Bill Acceptor Information

To interface to the Dixie-Narco USA-15 acceptor the following setting should be used for the “\$1 = one Pulse” configuration. See the acceptor manual for full details. Requires optional universal interface cable kit SCM P/N 4K00304.

The 18-pin interface jumper plug should not be used.

### 8.3 MDB Bill Acceptors

The following is list of MDB bill Acceptors that will work in the EC+ Machine Series:

Coinco        BA30B  
                 MAG50B  
                 BP2 & BP4

**Note:** The Coinco acceptor's use the small orange plug on the MDB cable the large plug will be unused.

Mars            AE2400  
                 AE2600

Cashcode      xxx-MCP-STxx-xxx  
                 xxx-MSH-STxx-xxx

See the bill acceptor manual for details on configuring for Multi-drop Bus operation.

**Note:** Bill accept and security switches will have to be set for money to be accepted.

### 9.0 Part Ordering Information

To obtain service on a component or module, please follow these instructions.

1. Locate the fault to a specific component or module.
2. Call your nearest Standard Change-Makers service center. You will need to give the service representative the following.

**MODEL NUMBER OF YOUR MACHINE**  
**SERIAL NUMBER OF YOUR MACHINE**

3. If you cannot furnish these numbers it will be extremely difficult for the service department to help you. The serial number and model number is located on a label inside your machine. Service center phone numbers are given on the last page of this manual.
4. Turn OFF the AC power with the master switch located on the system controller box or at the fuse panel of your building. Remove the faulty component from the changer cabinet.
5. If the component is to be returned to the factory or service center, pack the component in the original packaging used when the unit was shipped from the factory. If the original packaging is not available, use a suitable substitute. Care should be taken to prevent damage to the components from electrostatic discharge and mechanical shipping damage.

**NOTE:** Please avoid the use of Styrofoam "peanuts" when packing. If peanuts are used, the component should be encased in a plastic bag to prevent clogging the mechanism.

## 9.1 Service Part Numbers

### 9.1.1 Interconnecting cables

Part Number	Description
4C00218	AC Power Cord 9'
4C00265	AC Power Cord 9' Plug Both Ends
4C00228	Out Of Service cable
4C00224	Pulse Bill Acceptor Cable (Standard)
4C00230	Pulse Bill Acceptor Cable (MARS)
4C00225	Pulse Bill Acceptor Cable (Universal)
4C00269	MDB Bill Acceptor Cable 48"
4C00227	Mechanical Coin Acceptor Cable
4C00196	Electronic Coin Acceptor Cable 60"
4C00229	18 Pin Interface Plug

### 9.1.2 Module Part Numbers

Part Number	Description
4E00315	System Controller PCB W/O K.T.
4E00316	System Controller PCB W K.T.
5P00228	System Controller Complete Assembly W K.T.
5P00229	System Controller Complete Assembly W/O K.T.
5H00123	Quarter Dispenser
5H00124	Dollar / Quarter Dispenser
5C00126	ASAHI SEIKO Mechanical Coin Acceptor
5C00129	MARS Electronic Coin Acceptor
5M00171	UNINOTE Bill Dispenser – U.S. only
CALL	Bill Acceptor US MDB
CALL	Bill Acceptor US PULSE
CALL	Bill Acceptor CAN MDB
CALL	Bill Acceptor CAN PULSE

### 9.1.3 Coin Acceptor Kits

Kit includes coin acceptor, cable, and mounting hardware. Kit is for EC 200 models only.

Part Number	Description
4K00295	Electronic Coin Acceptor (Mars)

### 9.1.4 Universal Note Acceptor Cable Kit

Kit includes a universal note acceptor cable and an 18-pin interface plug.

Part Number	Description
4K00304	Universal Bill Acceptor Cable Kit

### 9.1.5 Miscellaneous Parts

Part Number	Description
1L00116	Out Of Service Lamp
1F00106	2AMP slow blow fuse

### 9.1.6 Coin Dispenser Type 1 Part Numbers

Location	Part Number	Description
Not Shown	4C00219	Controller to Dispenser Cable front load
Not Shown	4C00262	Controller to Dispenser Cable rear load
1A-1D	4M00533	Coin Dispenser Housing
2	4A00121	Coin Dispenser Funnel Assembly
Not Shown	4C00221	Sold-out Cable
3A	4M00533	Coin Dispenser Feed Mechanism – Quarter/Dollar*
3B	2P00105	Coin Dispenser Adapter Ring – Dollar*
3C	1M00112	Coin Dispenser Motor , DC
3D	2G00104	Motor Gear
3F	3P00102	Split Pin
3E	4C00220	Motor Harness
4	1E00110	Optional Counter
5	4C00217	Internal Dispenser Cable
6	4E00287	Coin Dispenser PCB Assembly
Not Shown	5M00171	Uninote Bill Dispenser – See Manual

**\*For other dispense mechanical sizes call for correct order number.**

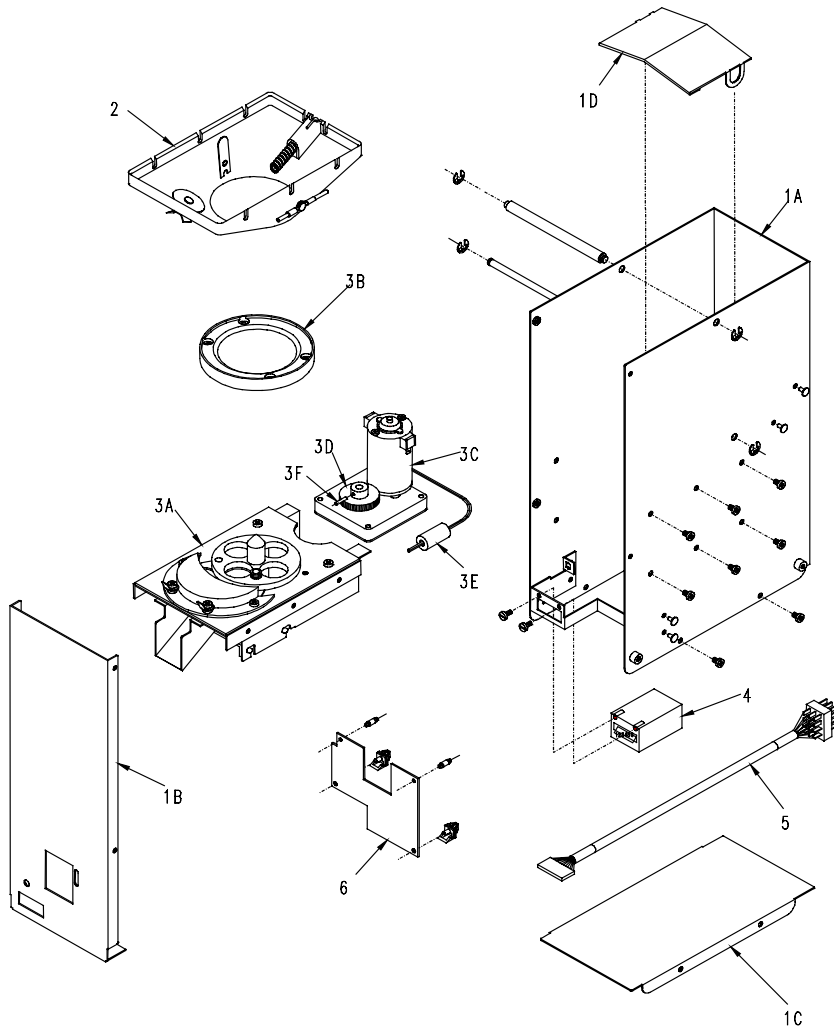

### 9.1.7 Coin Dispenser Type 2 Part Numbers

Location	Part Number	Description
Not Shown	4C00233	Controller to Dispenser Cable 60"
1A-1F	4M00170	Coin Dispenser Housing
2	4M00574	Hopper Tilt Stop Assembly
Not shown	4C00221	Sold-out Cable
3	4A00121	Coin Dispenser Funnel Assembly
4A	4M00568	Feed Mechanism – Quarter/Dollar*
4B	2P00101	Hopper Adapter Ring - Quarter*
5A	2F01272	Hopper PCB DC Retro Bracket
5B	4E00295	DC-AC Hopper PCB Assembly
6	4A00122	Hopper Interrupter Assembly
7	1M00113	Hopper Motor, DC

**\*For other dispense mechanical sizes call for correct order number.**

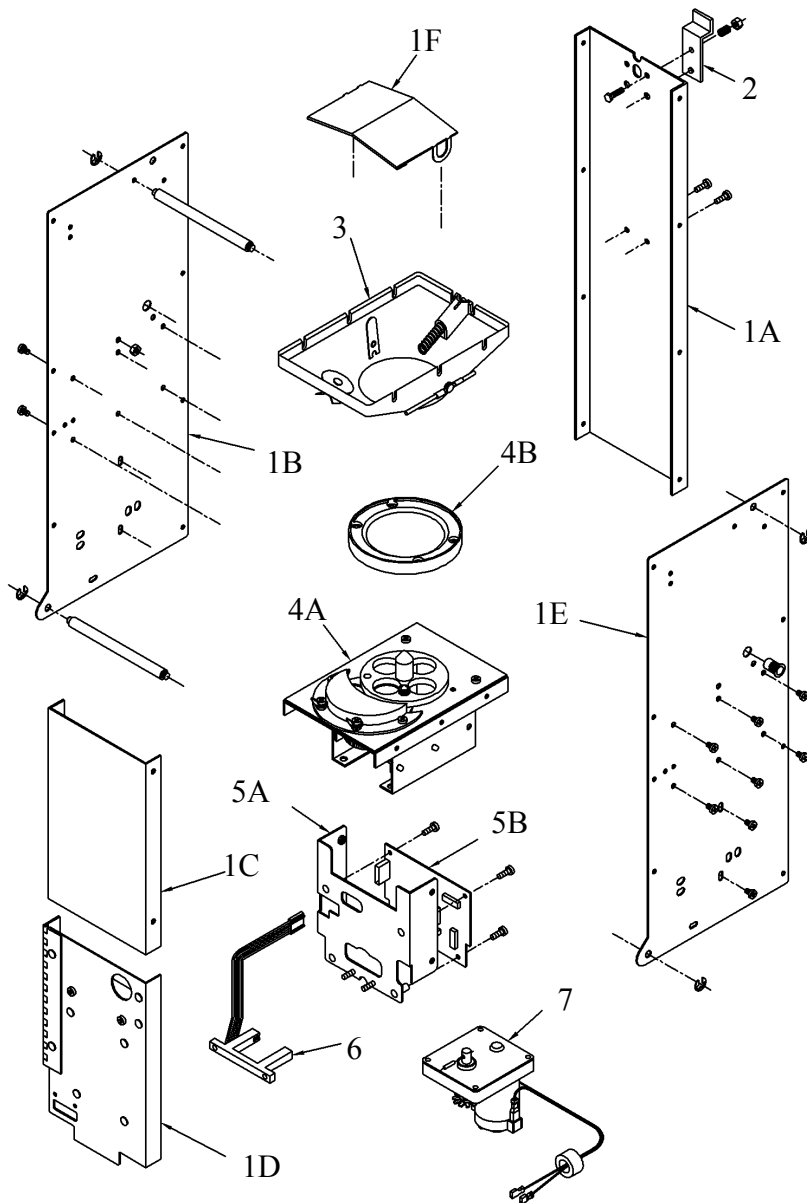

# APPENDIX A: EC100 Cabinet Mounting Holes and Stand Assembly

## EC100 Mounting Hole Locations

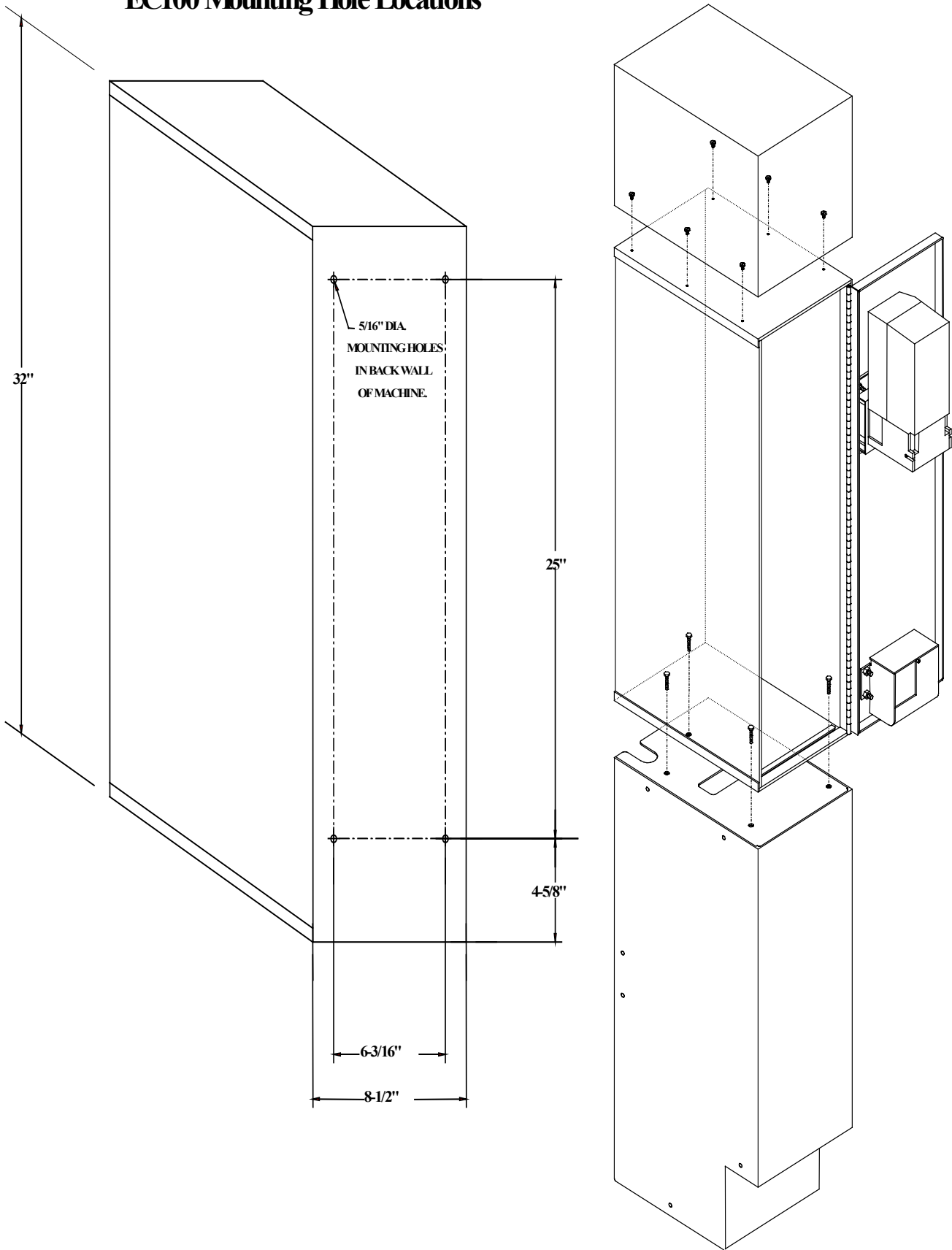

# APPENDIX B: EC200 Cabinet Mounting Holes

## EC200 Mounting Hole Locations

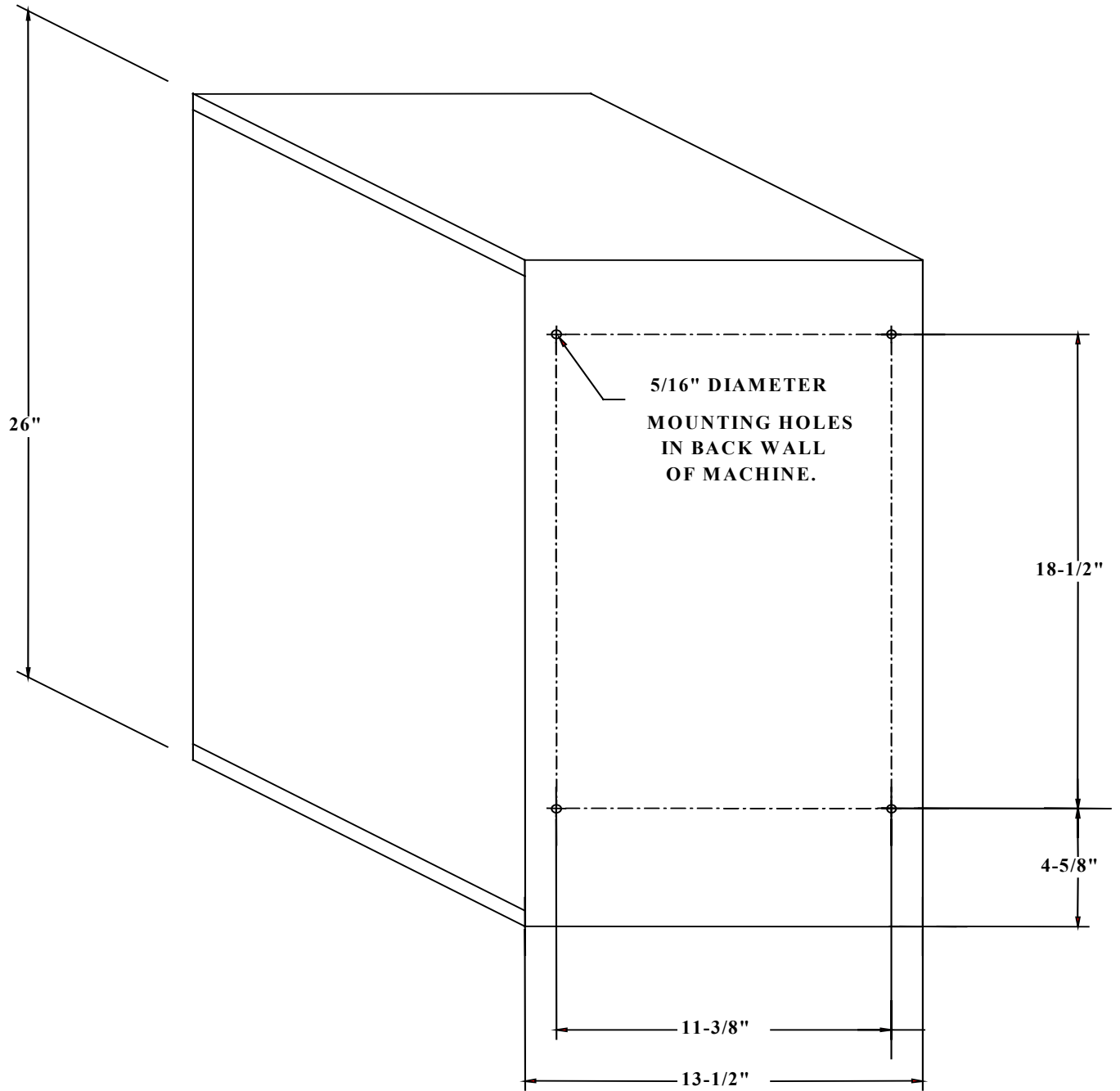



**APPENDIX C: EC200 Stand Assembly**

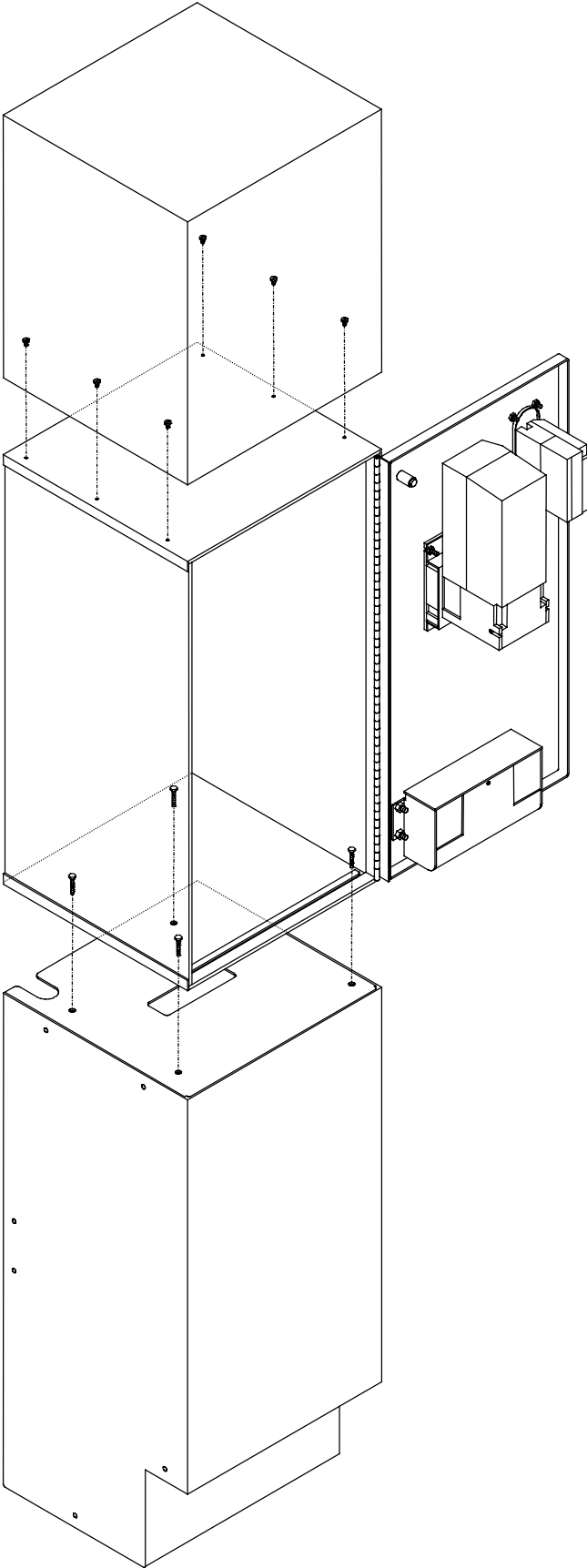

# APPENDIX D: RHINO Cabinet Mounting Holes

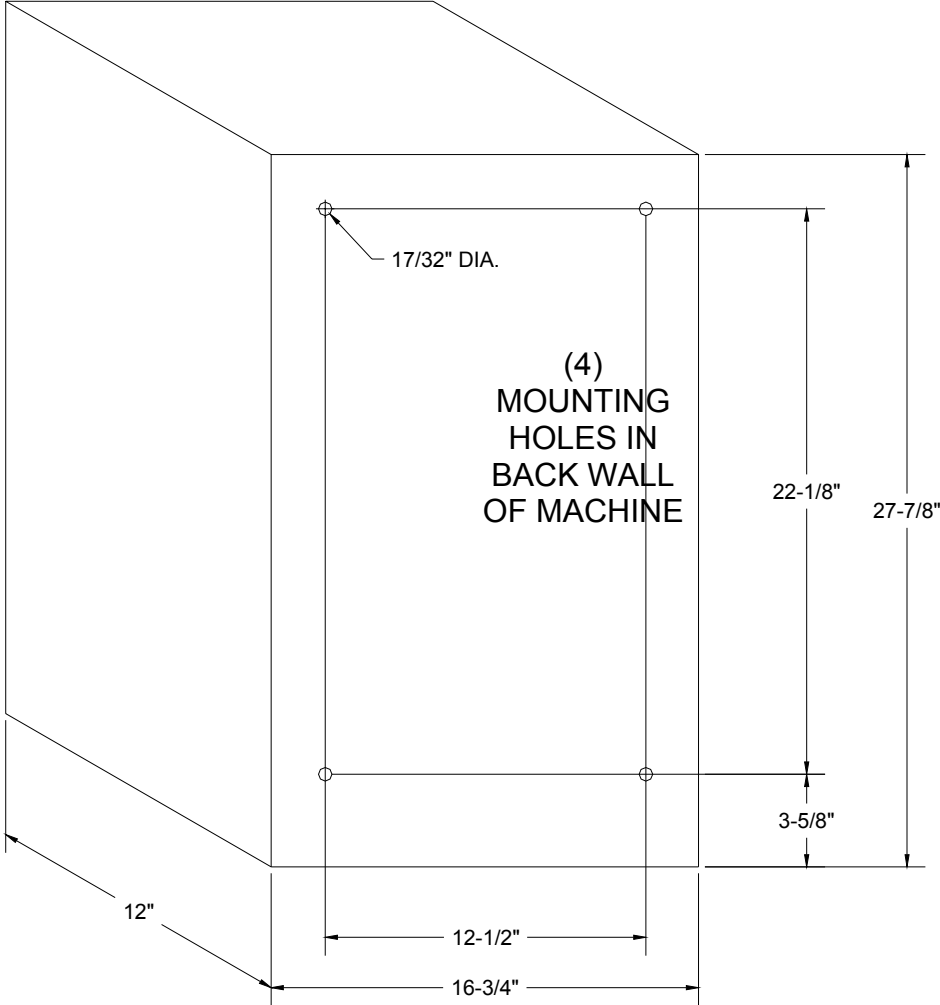

# APPENDIX E: RHINO Stand Assembly

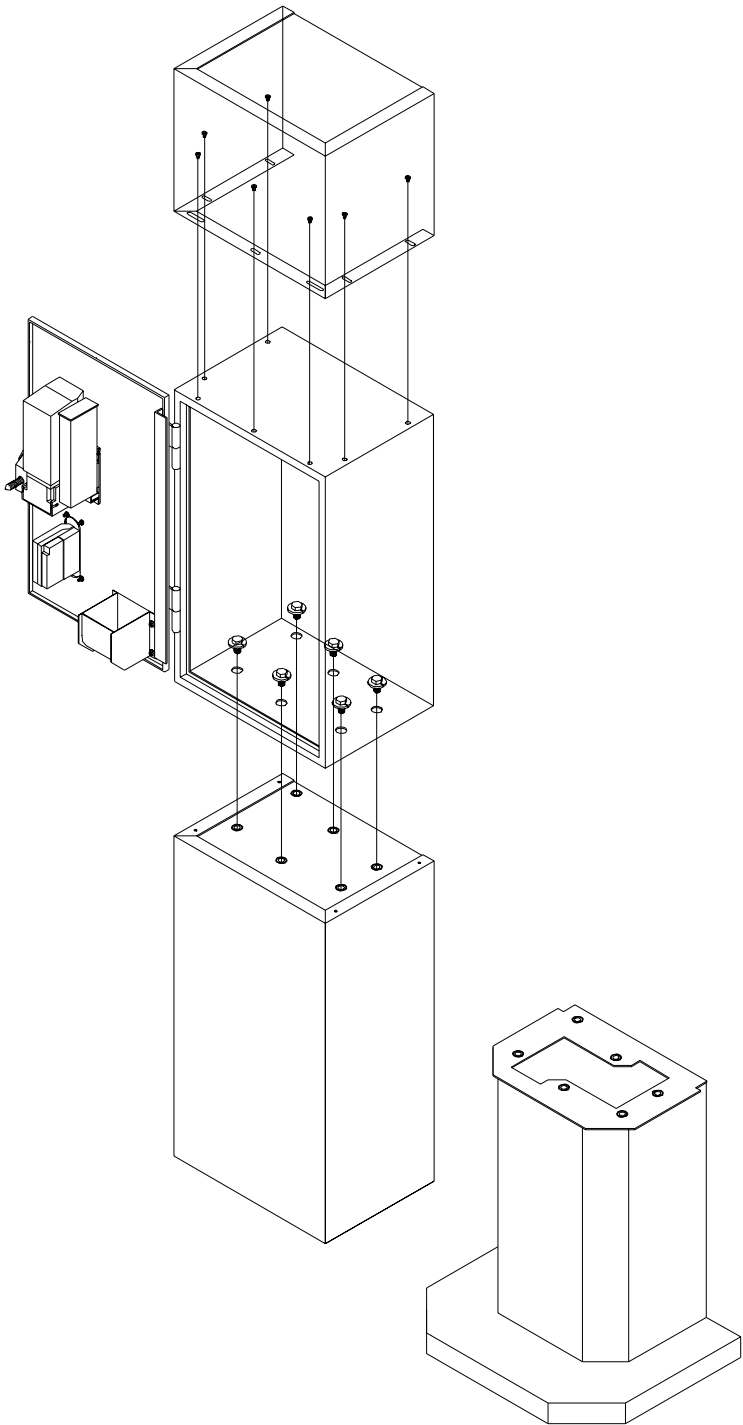

OPTIONAL:  
PEDESTAL BASE

**APPENDIX F: BCX1000 Cabinet Mounting Holes**

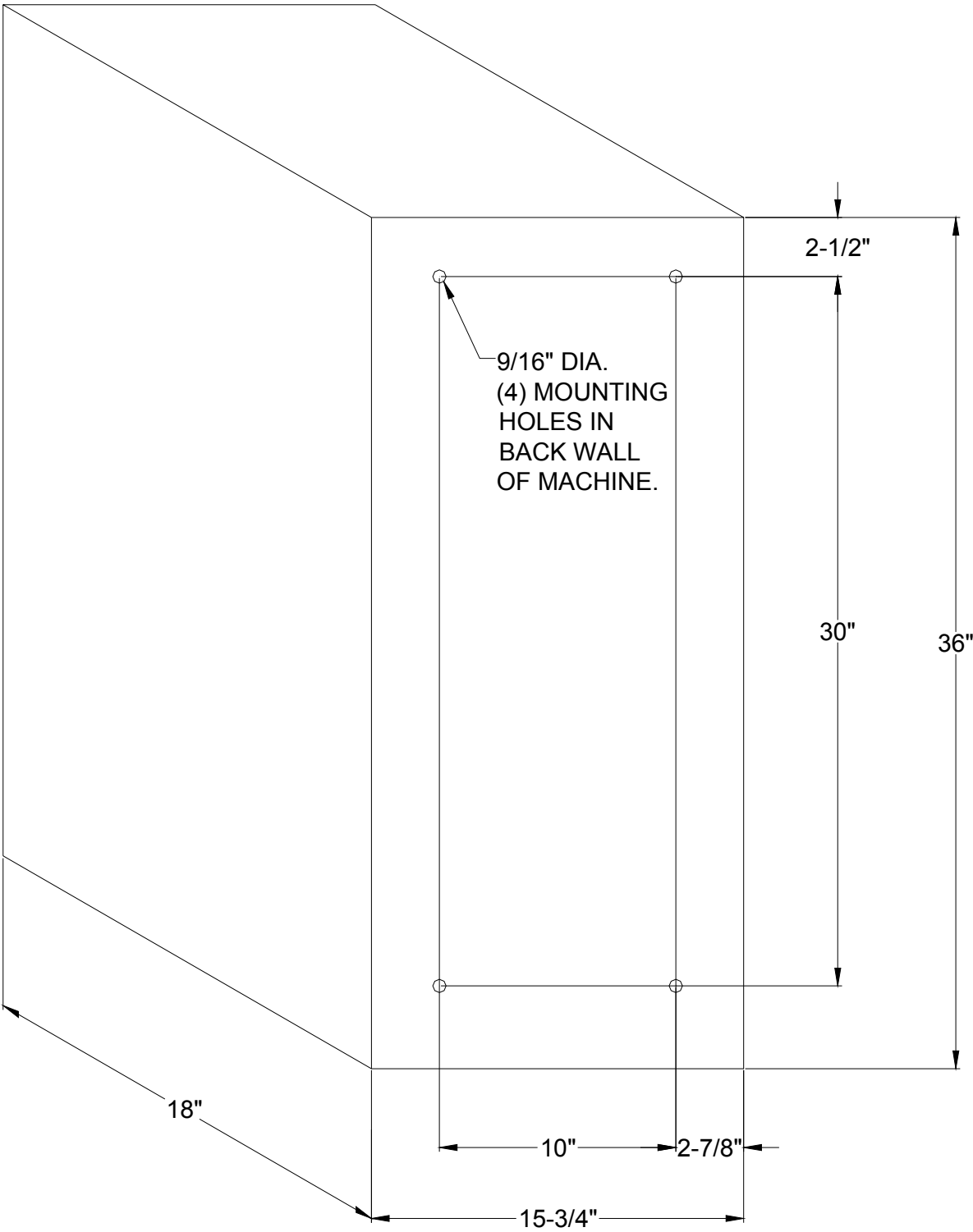

**APPENDIX G: BCX1000 Stand Assembly**

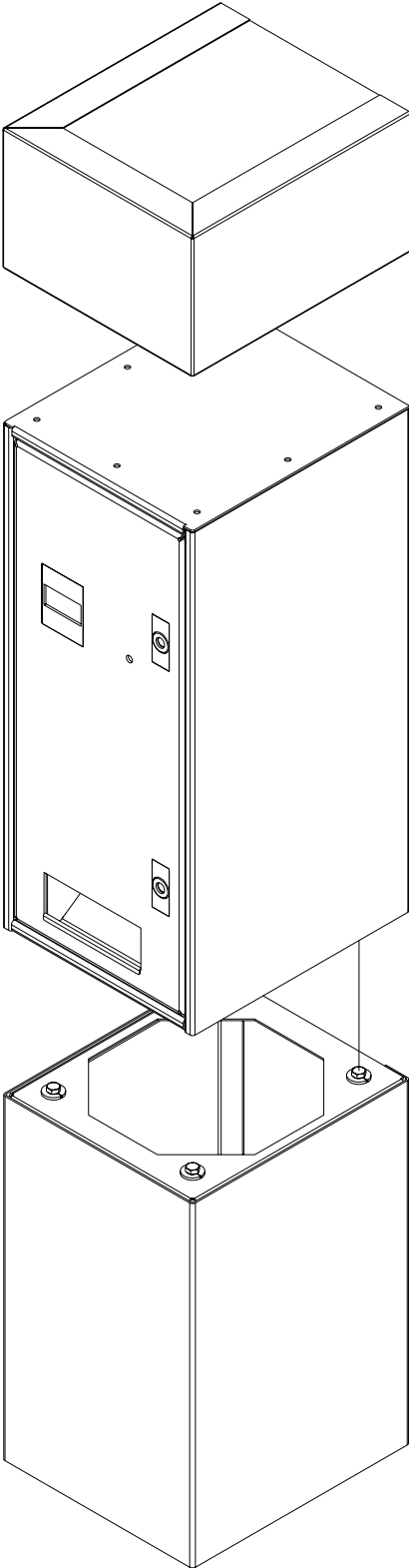

## APPENDIX H: Base Token Value Table

NOTE: If box is blank, switch setting is OFF

Value	SW3					
	1	2	3	4	5	6
Dispenser Inactive						
\$.05						On
\$.10					On	
\$.15					On	On
\$.20				On		
\$.25				On		On
\$.30				On	On	
\$.35				On	On	On
\$.40			On			
\$.45			On			On
\$.50			On		On	
\$.55			On		On	On
\$.60			On	On		
\$.65			On	On		On
\$.70			On	On	On	
\$.75			On	On	On	On
\$.80		On				
\$.85		On				On
\$.90		On			On	
\$.95		On			On	On
\$1.00		On		On		
\$1.05		On		On		On
\$1.10		On		On	On	
\$1.15		On		On	On	On
\$1.20		On	On			
\$1.25		On	On			On
\$1.30		On	On		On	
\$1.35		On	On		On	On
\$1.40		On	On	On		
\$1.45		On	On	On		On
\$1.50		On	On	On	On	
\$1.55		On	On	On	On	On
\$1.60	On					
\$1.65	On					On
\$1.70	On				On	
\$1.75	On				On	On
\$1.80	On			On		
\$1.85	On			On		On
\$1.90	On			On	On	
\$1.95	On			On	On	On
\$2.00	On		On			

## APPENDIX I: Bonus Token Amount Table

NOTE: If box is blank, switch setting is OFF

Bonus Dispense amount for:					SW3		SW5				
\$1	\$2	\$5	\$10	\$20	7	8	1	2	3	4	5
0	0	0	0	0							
0	0	0	0	10							On
0	0	0	1	2						On	
0	0	0	1	3						On	On
0	0	0	1	4					On		
0	0	0	2	4					On		On
0	0	0	2	5					On	On	
0	0	0	2	6					On	On	On
0	0	0	5	10				On			
0	0	0	5	20				On			On
0	0	1	2	4				On		On	
0	0	1	2	5				On		On	On
0	0	1	2	6				On	On		
0	0	1	3	6				On	On		On
0	0	1	3	7				On	On	On	
0	0	1	3	8				On	On	On	On
0	0	1	4	8			On				
0	0	1	4	9			On				On
0	0	1	4	10			On			On	
0	0	1	5	12			On			On	On
0	0	3	7	15			On		On		
0	0	5	8	10			On		On		On
0	0	5	20	40			On		On	On	
0	1	1	6	11			On		On	On	On
0	1	2	4	8			On	On			
0	1	2	5	10			On	On			On
0	1	2	5	11			On	On		On	
0	1	2	5	12			On	On		On	On
0	1	2	6	12			On	On	On		
0	1	2	6	14			On	On	On		On
0	1	2	6	15			On	On	On	On	
0	1	3	6	12			On	On	On	On	On
0	1	3	7	14		On					
0	1	3	7	15		On					On
0	1	3	7	16		On				On	
0	1	3	8	16		On				On	On
0	1	3	8	17		On			On		
0	2	5	10	20		On			On		On
0	2	5	10	21		On			On	On	
0	2	5	10	22		On			On	On	On
0	2	5	11	22		On		On			
0	2	5	11	23		On		On			On
0	2	5	11	24		On		On		On	
0	2	5	12	24		On		On		On	On
0	2	5	12	25		On		On	On		
0	2	5	12	26		On		On	On		On
0	2	6	12	24		On		On	On	On	
0	2	6	12	25		On		On	On	On	On
0	2	6	12	26		On	On				
0	2	6	14	28		On	On				On

**APPENDIX I: Bonus Table (Continued)**

Bonus Dispense amount for:					SW3		SW5				
\$1	\$2	\$5	\$10	\$20	7	8	1	2	3	4	5
0	2	6	14	29		On	On			On	
0	2	6	14	30		On	On			On	On
0	2	7	14	28		On	On		On		
0	2	7	14	29		On	On		On		On
0	2	7	14	30		On	On		On	On	
0	2	7	15	30		On	On		On	On	On
0	2	7	15	31		On	On	On			
0	2	7	15	32		On	On	On			On
0	2	7	15	33		On	On	On		On	
0	2	7	16	32		On	On	On		On	On
0	2	7	16	33		On	On	On	On		
0	2	7	16	34		On	On	On	On		On
0	2	7	16	35		On	On	On	On	On	
1	2	5	10	20		On	On	On	On	On	On
1	2	5	10	21	On						
1	2	5	10	22	On						On
1	2	5	10	23	On					On	
1	2	5	10	24	On					On	On
1	2	5	11	22	On				On		
1	2	5	11	23	On				On		On
1	2	5	12	24	On				On	On	
1	2	5	12	25	On				On	On	On
1	2	6	12	24	On			On			
1	2	6	12	25	On			On			On
1	2	6	13	26	On			On		On	
1	2	6	13	27	On			On		On	On
1	2	6	14	28	On			On	On		
1	2	7	14	28	On			On	On		On
1	2	7	14	29	On			On	On	On	
1	2	7	14	30	On			On	On	On	On
1	2	7	15	30	On		On				
1	2	7	15	31	On		On				On
1	3	6	12	24	On		On			On	
1	3	6	12	25	On		On			On	On
1	3	6	12	26	On		On		On		
1	3	6	12	27	On		On		On		On
1	3	6	14	28	On		On		On	On	
1	3	6	14	29	On		On		On	On	On
1	3	6	14	30	On		On	On			
0	0	0	10	20	On		On	On			On
0	0	0	12	24	On		On	On		On	



## APPENDIX J: Pulse Bill Acceptor Cable Pinouts

This appendix shows the connector pinout at the Pulse Bill Acceptor end of the Economy Changer cables. **Note:** Connectors are not on all cables.

Connector  
Molex 09-50-3091

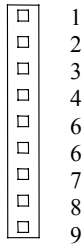

Pin	Wire Color	Function
1	Gray	Ground
2	Brown	Bill acceptor pulse output
3		
4		
5	White/green	110VAC Neutral
6		
7		
8	White	Bill acceptor Inhibit 110VAC HOT
9	Black	110VAC Hot

Connector  
AMP 172161-1

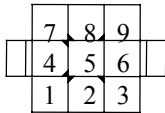

Pin	Wire Color	Function
1	White/green	110VAC Neutral
2	White/green	110VAC Neutral
3	White	Bill acceptor Inhibit 110VAC HOT
4	White	Bill acceptor Inhibit 110VAC HOT
5		
6	White/green	110VAC Neutral
7	Brown	Bill acceptor pulse output
8	Gray	Ground
9		

Connector  
AMP 172170-1

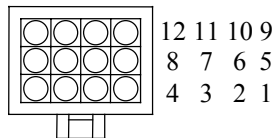

Pin	Wire Color	Function
1	Black	110VAC Hot
2	White/green	110VAC Neutral
3		
4	Brown	Bill acceptor pulse output
5	Gray	Ground
6		
7	White	Bill acceptor Inhibit 110VAC HOT
8	White/green	110VAC Neutral
9		
10		
11		
12		

Connector  
AMP 1-480705-0

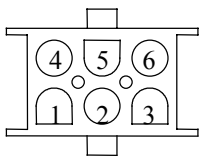

Pin	Wire Color	Function
1	Brown	Bill acceptor pulse output
2	Gray	Ground
3		
4		
5		
6		

Connector  
Molex 19-09-1049

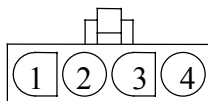

Pin	Wire Color	Function
1	Black	110VAC Hot
2	White/green	110VAC Neutral
3	White	Bill acceptor Inhibit 110VAC HOT
4		

## APPENDIX K: Master Program Chip Installation Instructions

Occasionally there is a need to upgrade the Master Program Chip to add new features that have been designed into this product line. With this easy six-step procedure, you can install the latest features without the “downtime” associated with sending a component to a service center. The software included with this notice contains improvements for coin and bill dispensing as well as increased protection against theft. We highly recommend that you take the time to update your current software.

**Note: Be aware that ESD (Electro-Static-Discharge) can damage components on this circuit board. Be sure you have discharged any static electricity you may have built up by touching the cabinet, and before handling the program chip.**

1. Turn power off and disconnect all cables attached to the control panel.
2. Remove the lower cover by unfastening the two 7/16” nuts as shown below.
3. **Prior to removing the Master Program Chip**, notice that it is a 28-pin chip in a 32-pin socket, and that the left side four (4) pins are not used. The new chip must be inserted in the same manner. Remove the Program Chip by gently prying it out with a small straight edge screwdriver.
4. Carefully install the new program chip. This must be inserted in the same direction and location of the program chip you just removed.
5. Replace the lower cover and reconnect all cables to their original connectors.
6. Power up the machine and test for proper operation.

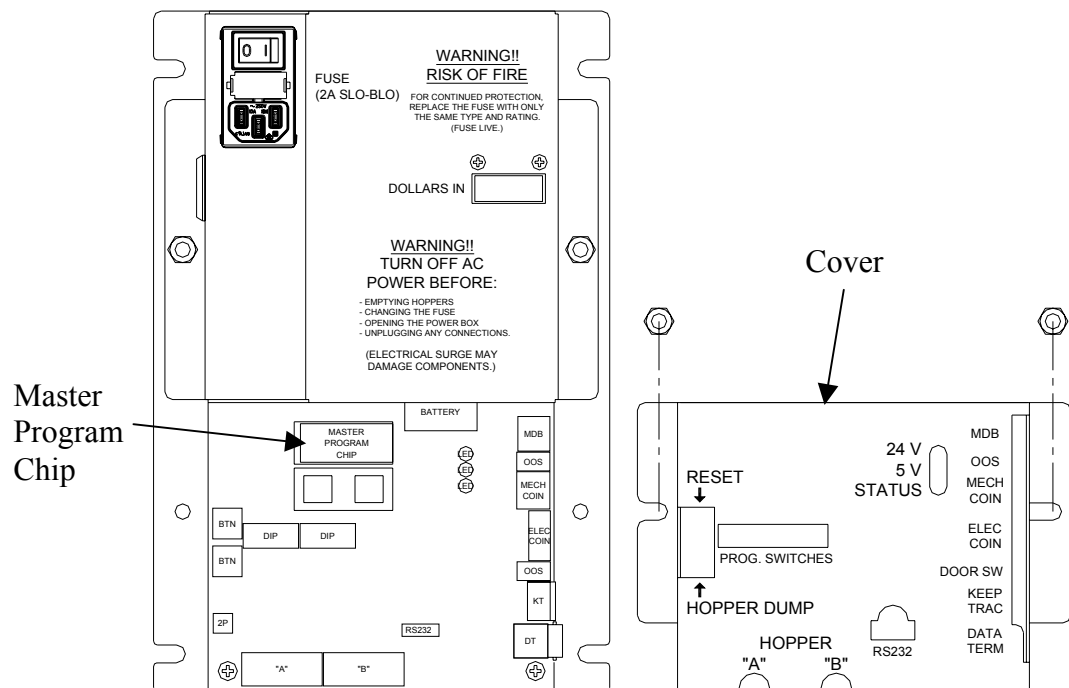

**Standard Change-Makers  
Service Centers**

**Standard Change-Makers – Central Region**

**Factory and Home Office**

P.O. Box 36550

Indianapolis, IN 46236-0550

3130 North Mitthoeffer Road

Indianapolis, IN 46235-0550

(317) 899-6966

800-968-6955

FAX (317) 899-6977

WEB: [www.standardchange.com](http://www.standardchange.com)

**Standard Change-Makers – Eastern Region**

507 Dutton Mill Road, Suite G

Aston, PA 19014

(866) 394-5412

FAX (610) 859-0627

**Standard Change-Makers – Western Region**

11731 Telegraph Road, Suite C

Santa Fe Springs, CA 90670

(866) 394-5411

FAX (562) 801-1180

**Standard Change-Makers – Canada**

6020 Van Den Abeele

St. Laurent, Quebec

Canada H4S 1R9

(514) 332-2196

FAX (514) 332-3963

**Record these numbers here for use when ordering parts.**

**Serial #** \_\_\_\_\_

**Model #** \_\_\_\_\_